

A SECTION 'A'
ON-SITE SECTION NTS

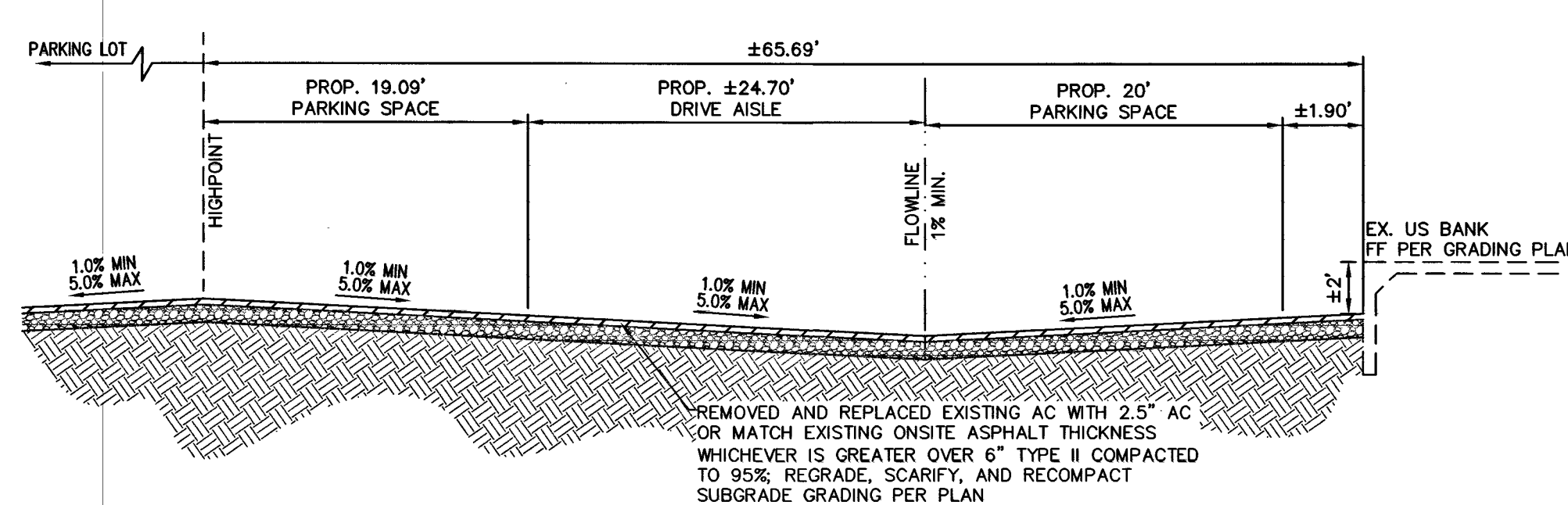

F SECTION 'F'
ON-SITE SECTION NTS

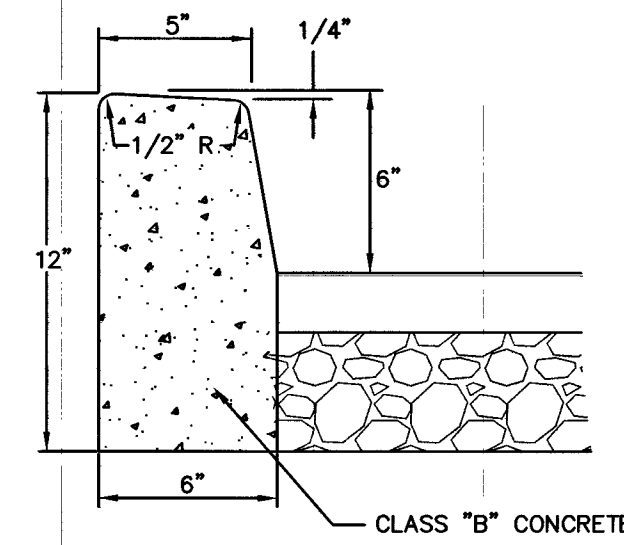

1 TYPE 'A' CURB SECTION NTS

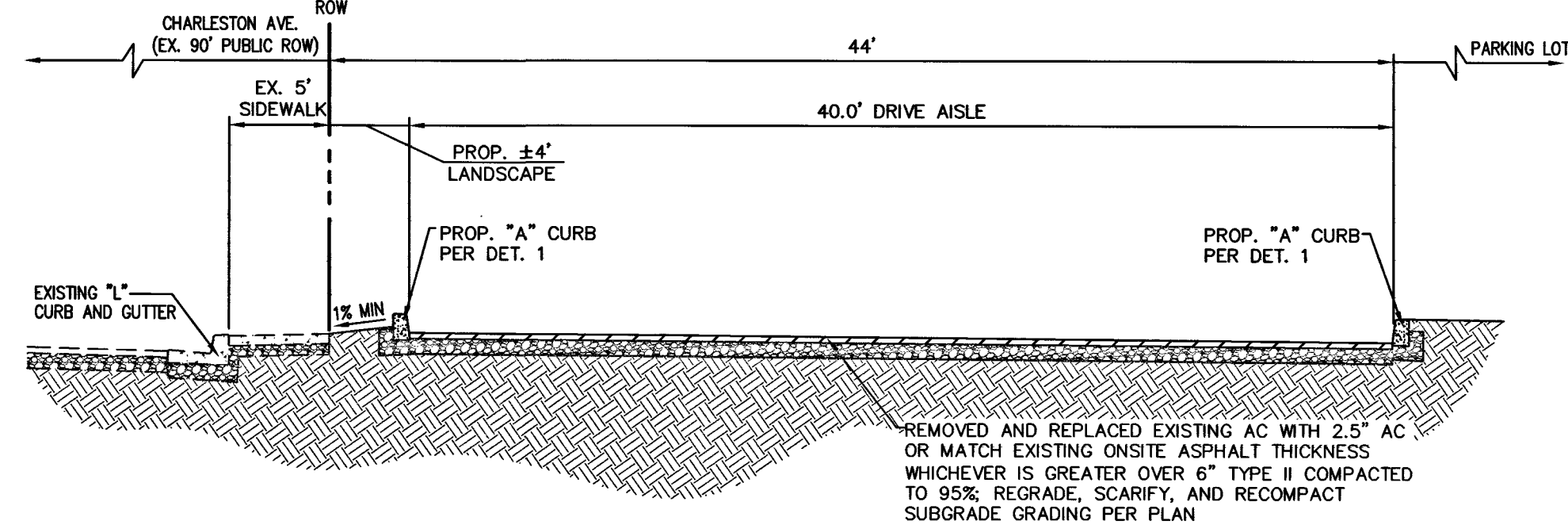

B SECTION 'B'
ON-SITE SECTION NTS

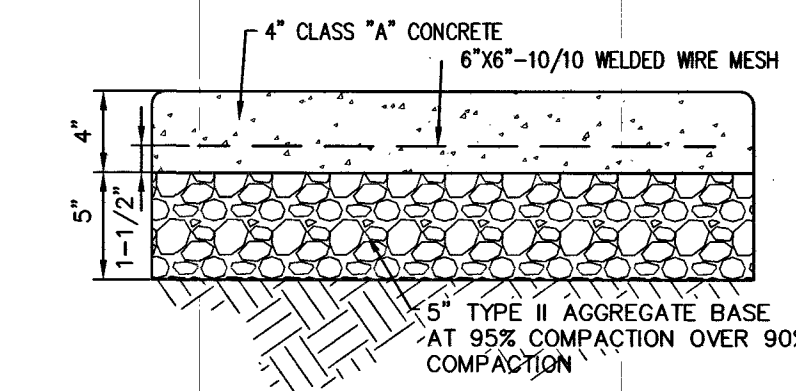

2 REINFORCED CONCRETE DETAIL NTS

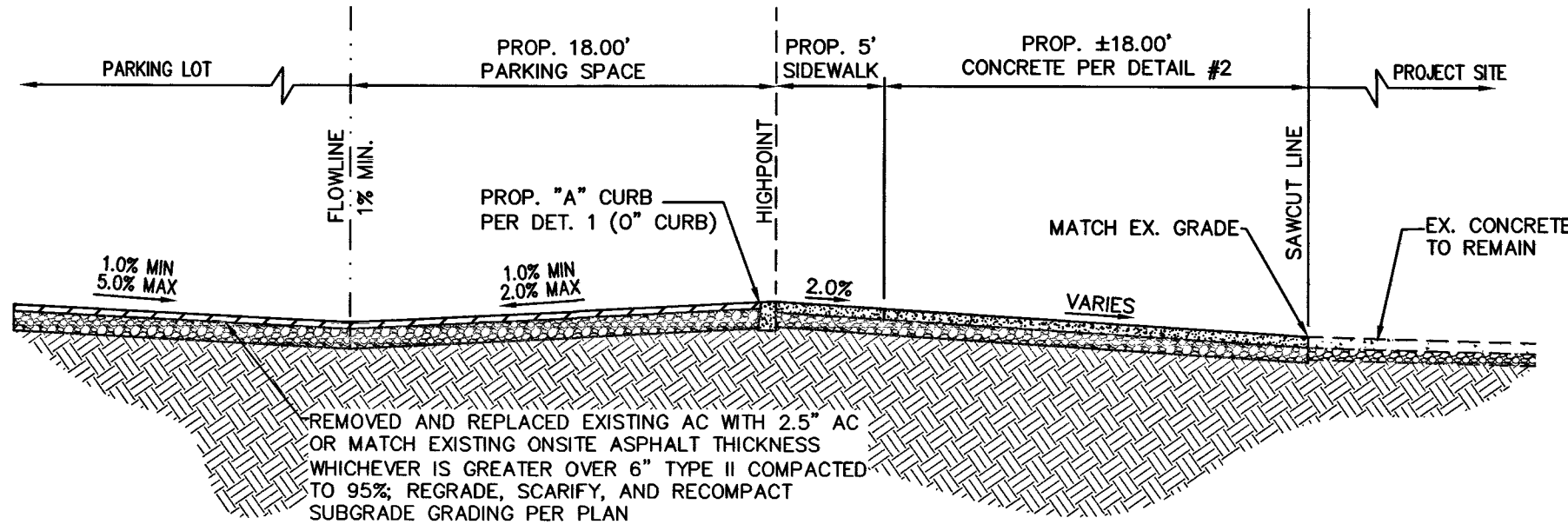

C SECTION 'C'
ON-SITE SECTION NTS

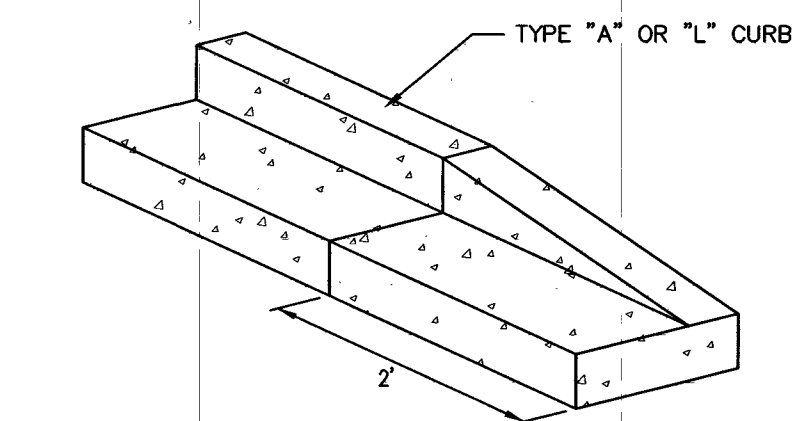

3 2' CURB TAPARED END DETAIL NTS

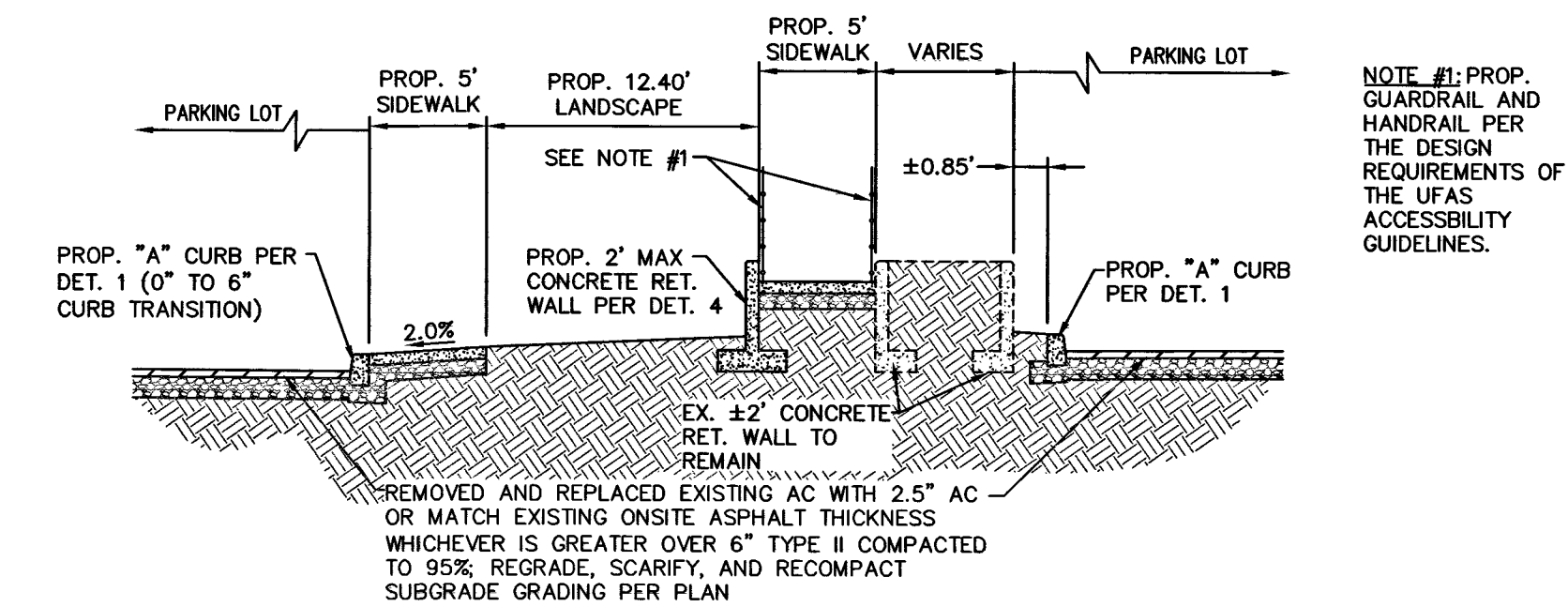

D SECTION 'D'
ON-SITE SECTION NTS

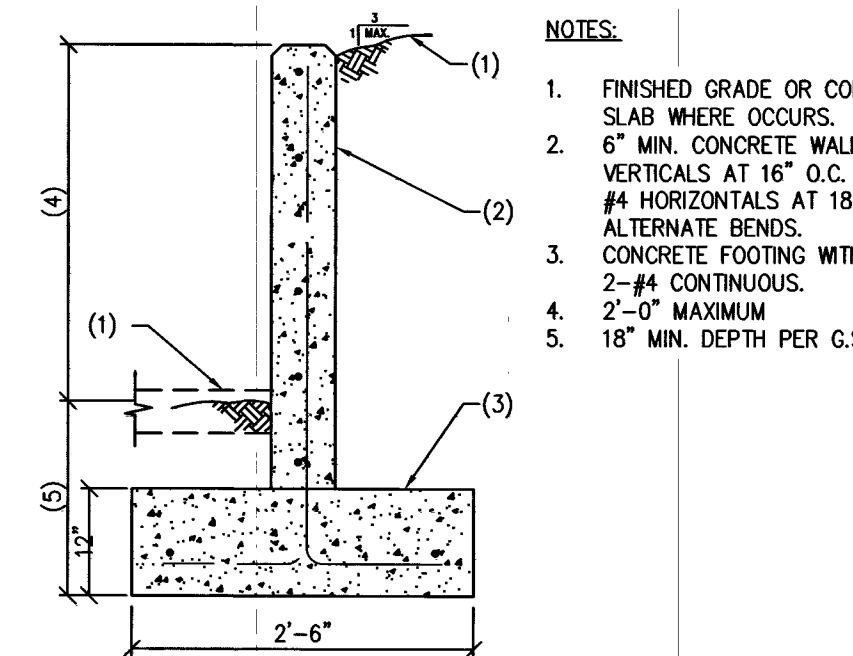

4 2' MAX CONC. RET. WALL DETAIL (CAST-IN-PLACE CONCRETE WALLS) NTS

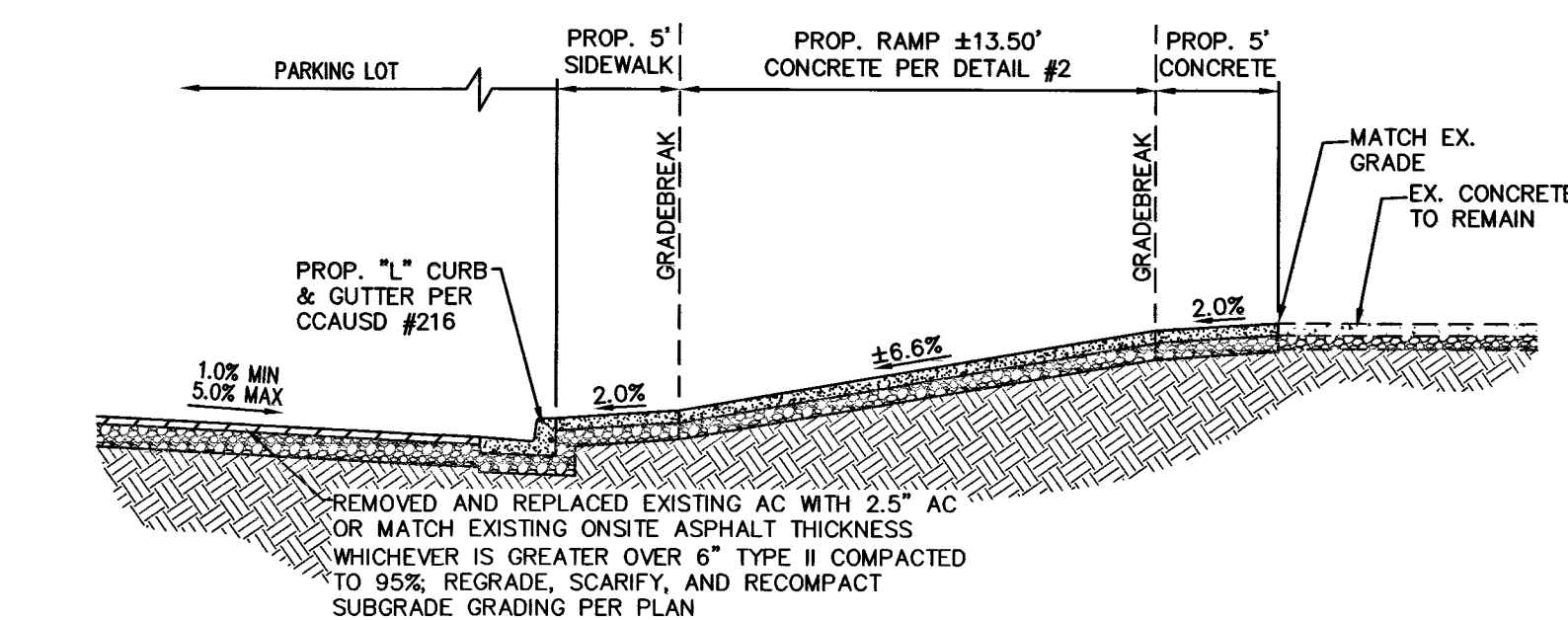

E SECTION 'E'
ON-SITE SECTION NTS

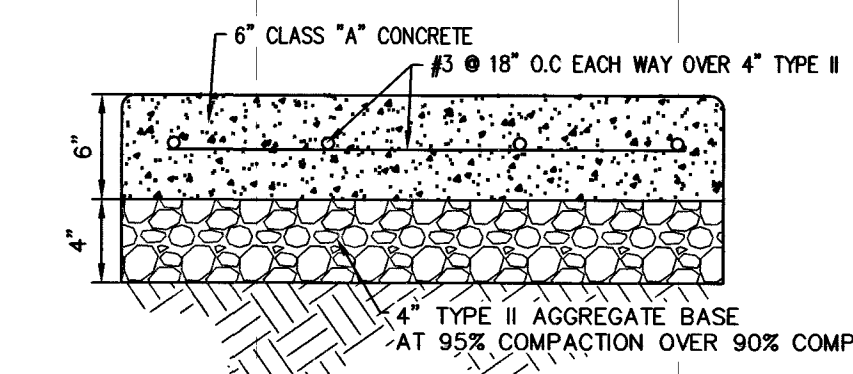

5 TRAFFIC RATED CONCRETE DETAIL (REINFORCED) NTS

JPL ENGINEERING INC.

6725 S. EASTERN AVE., STE. 500, LAS VEGAS, NV 89119
PHONE (702) 898-6288 FAX (877) 557-8292

**US BANK-CHARLESTON BRANCH
PARKING LOT REHABILITATION**

DETAIL SHEET

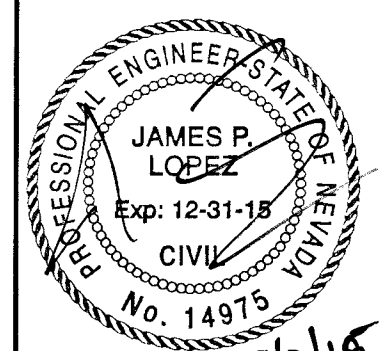

JOB#14-006
SHEET

DT

6 OF 6
CLV#60713

REV	DATE	DESCRIPTION	APPROVAL

SEPTEMBER, 2015

512-87