

SPECIFICATION REFERENCE	UNIFORM STANDARD DRAWINGS CLARK COUNTY AREA
	CITY OF LAS VEGAS ONLY THRU-LOT DRAIN (DETAIL FOR BOLLARDS) NOT FOR USE IN EMERGENCY ACCESS
	DATE 03-07-02 DWG. NO. 421 A PAGE NO. 120 B

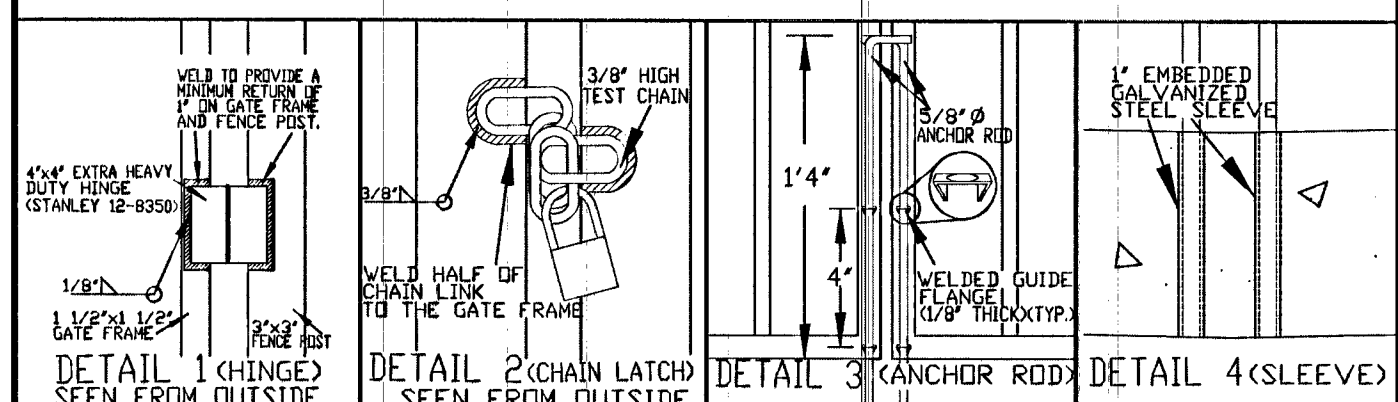

SPECIFICATION REFERENCE	UNIFORM STANDARD DRAWINGS CLARK COUNTY AREA
	CITY OF LAS VEGAS ONLY THRU-LOT DRAIN (DETAIL FOR FENCE) NOT FOR USE IN EMERGENCY ACCESS
	DATE 03-07-02 DWG. NO. 421 B PAGE NO. 120 C

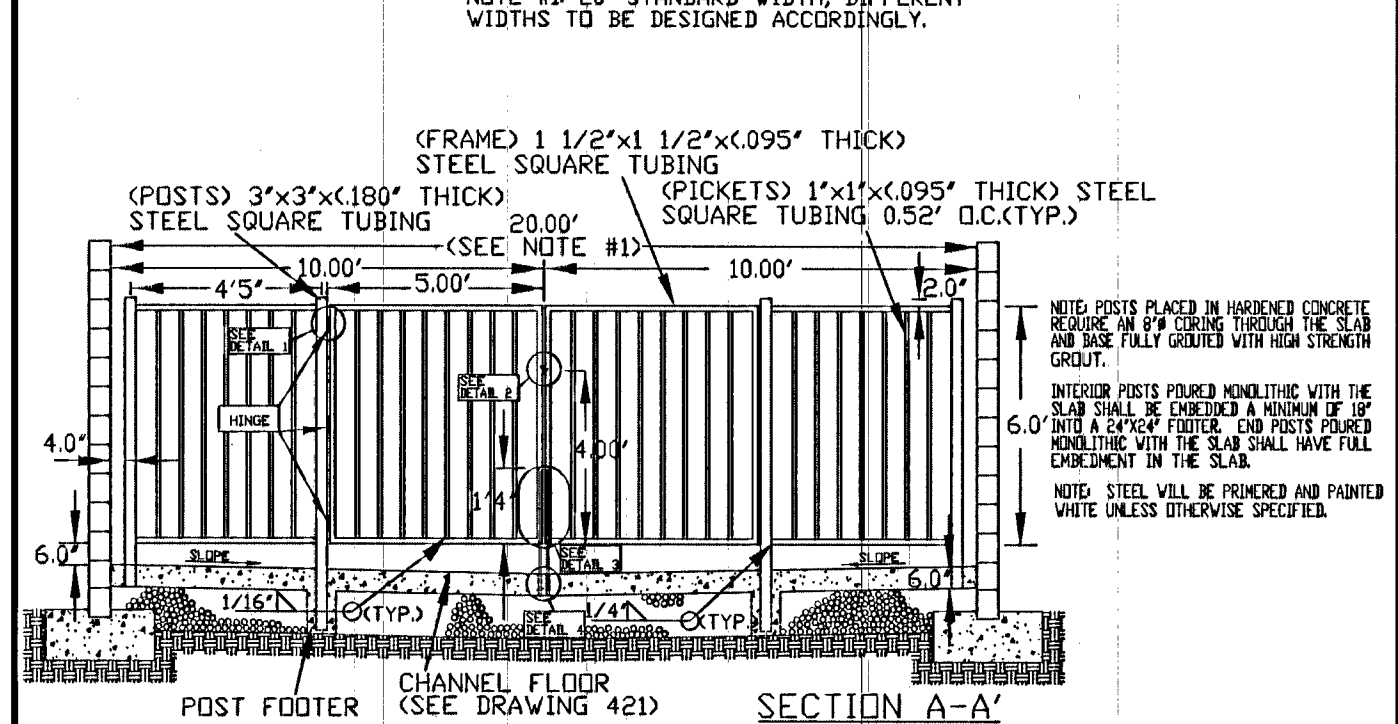
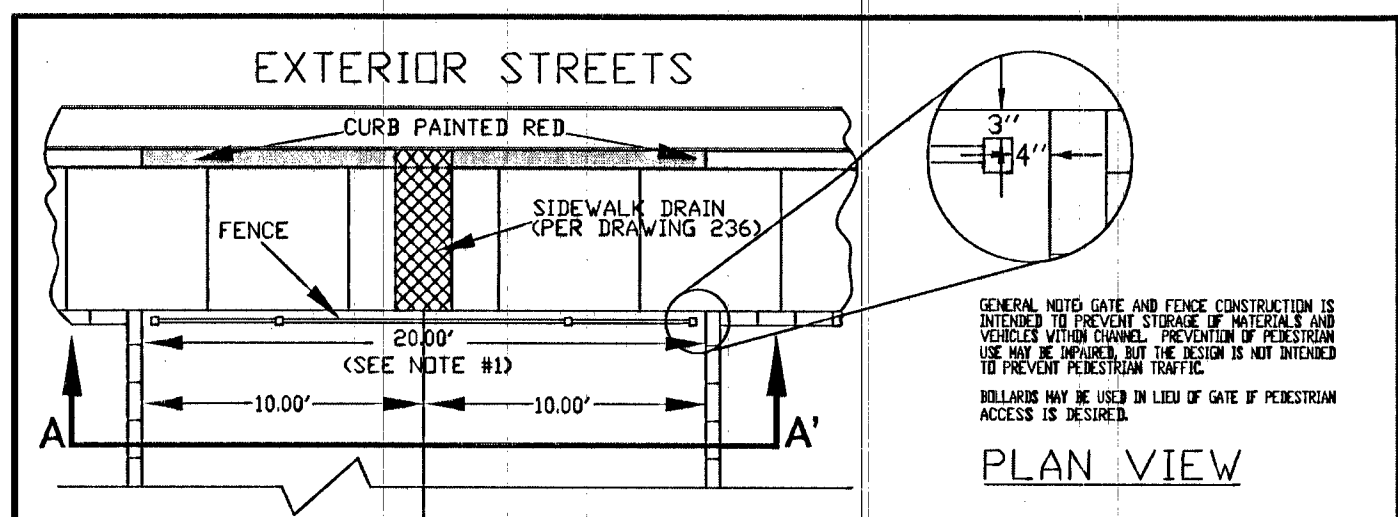
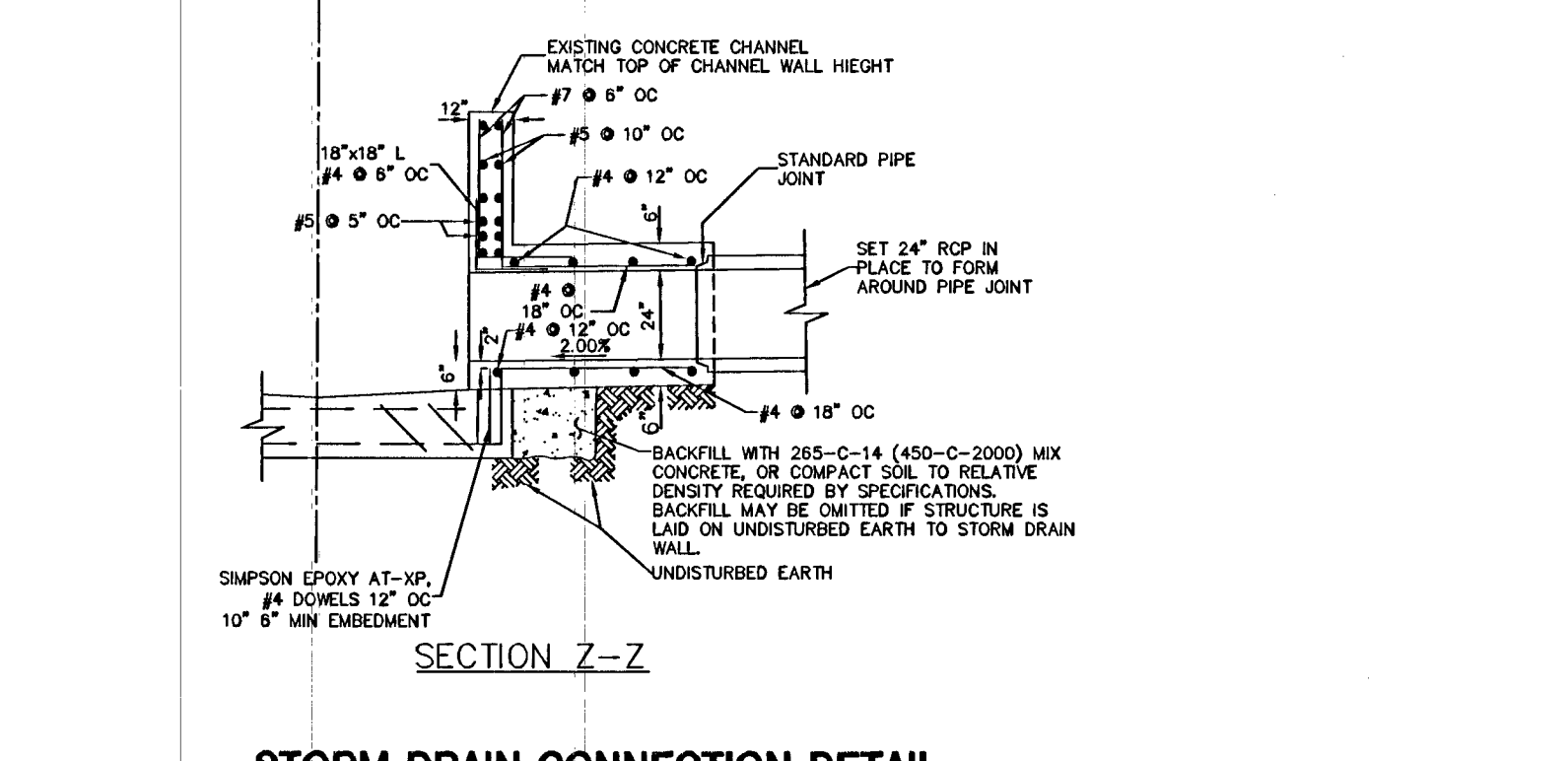
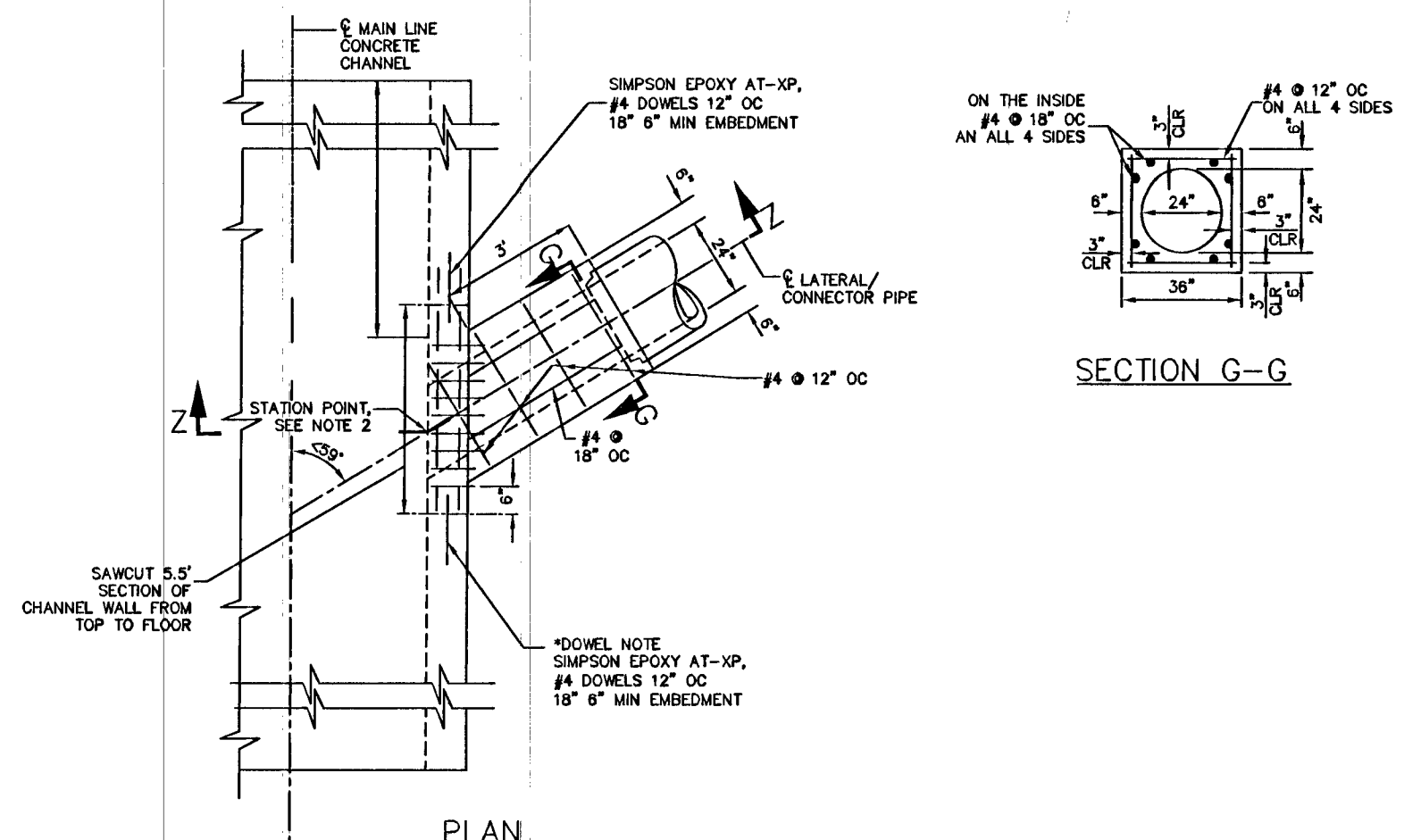

SPECIFICATION REFERENCE	UNIFORM STANDARD DRAWINGS CLARK COUNTY AREA
	CITY OF LAS VEGAS ONLY THRU-LOT DRAIN (DETAIL FOR FENCE) NOT FOR USE IN EMERGENCY ACCESS
	DATE 03-07-02 DWG. NO. 421 B PAGE NO. 120 C

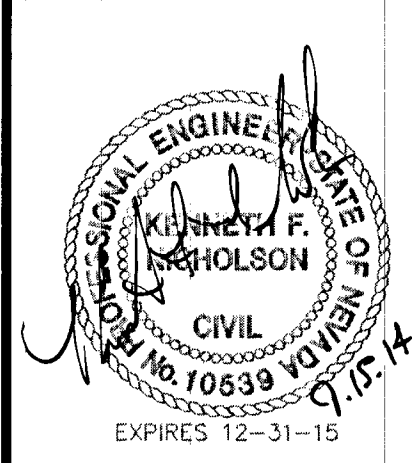
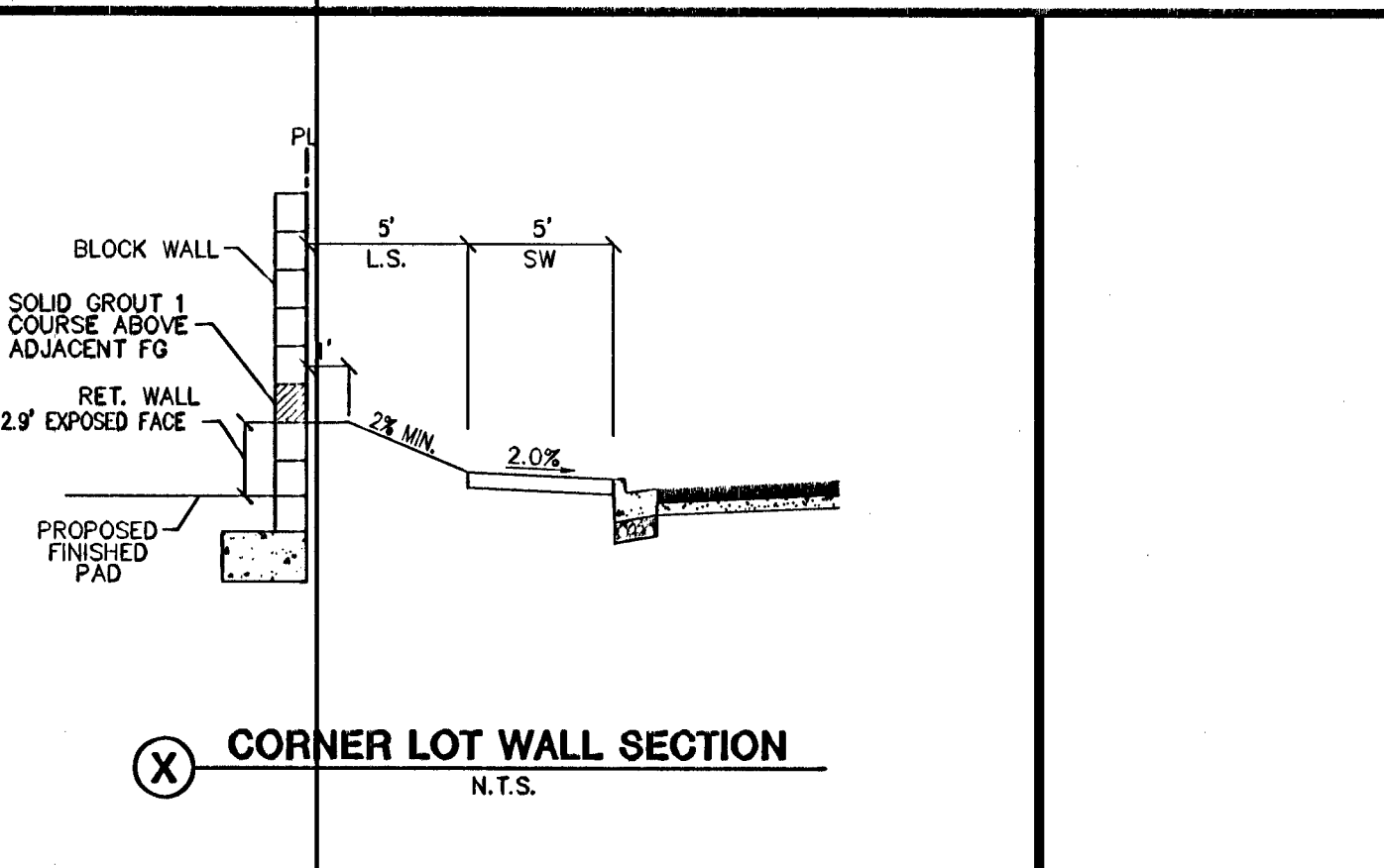
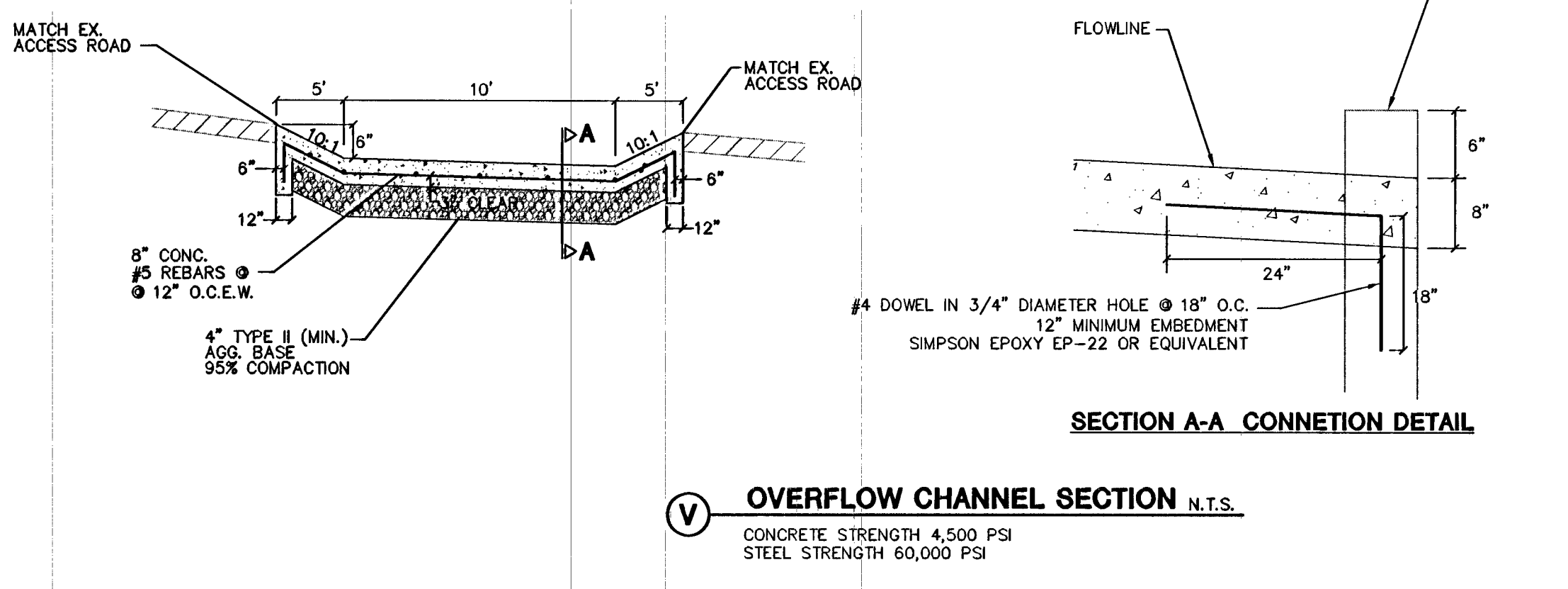
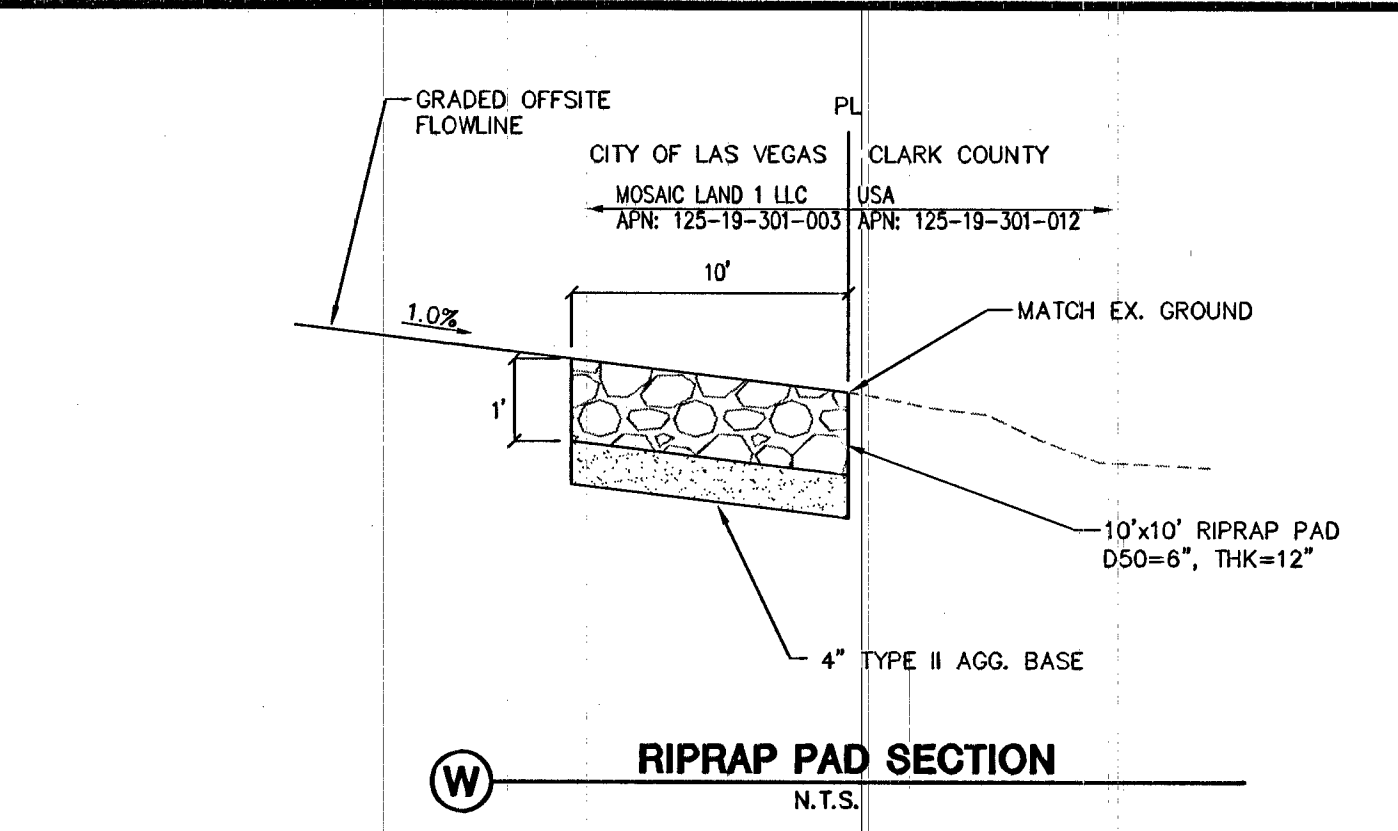
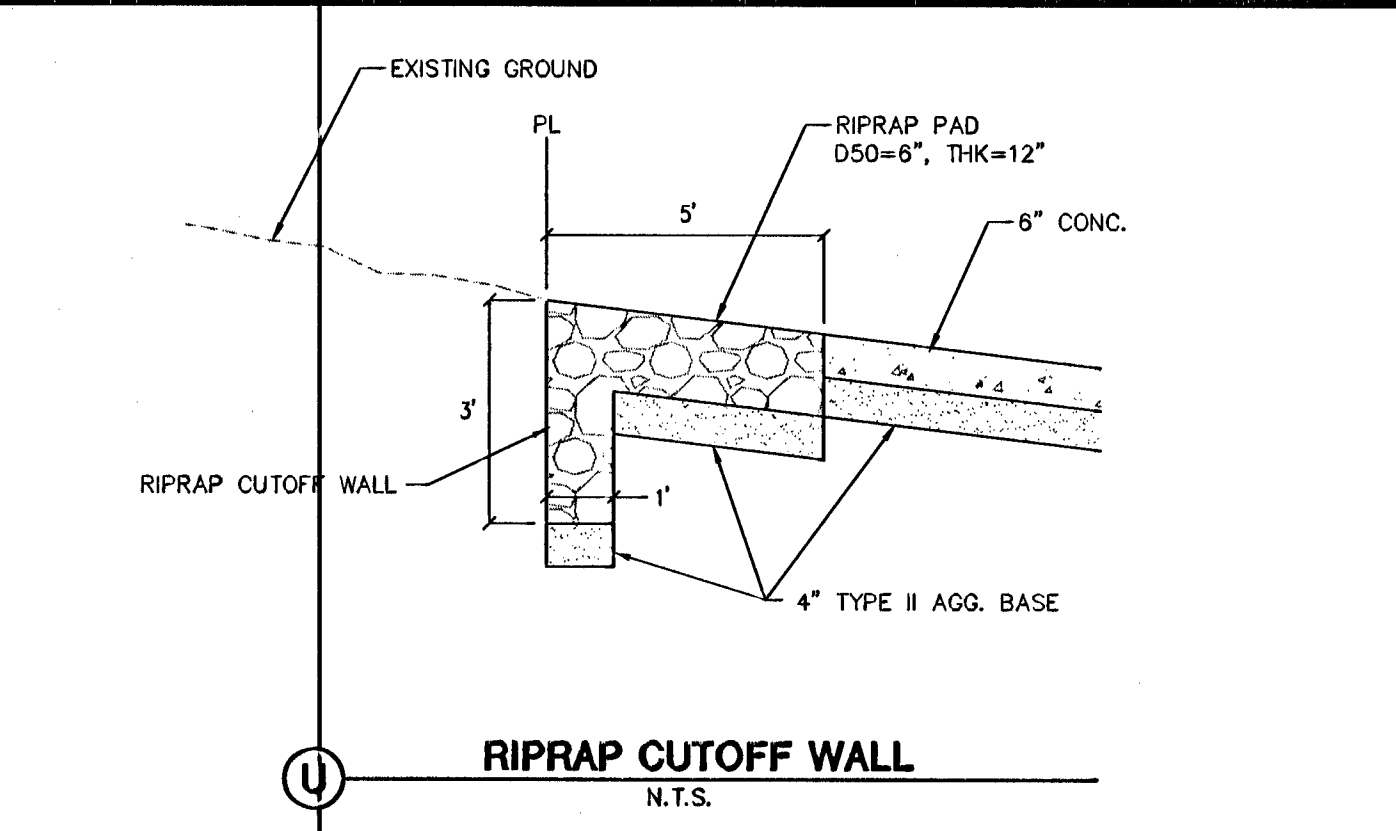

RYLAND HOMES		CITY OF LAS VEGAS	
8925 W. RUSSELL ROAD, SUITE 200 LAS VEGAS, NV. 89148 (702) 580-7500		2727 SOUTH RAINBOW BOULEVARD LAS VEGAS, NEVADA 89146-5148 PH. (702) 872-7550 FAX (702) 362-2287 WEB WWW.VTMV.COM CONSULTING ENGINEERS • PLANNERS • LAND SURVEYORS	
GRADING DETAILS 2		BRISTLE FALLS UNIT 2	
DRAWN BY: EM	DESIGNED BY: AY	CHECKED BY: AY	PROJECT NO: 7219
MAY 2013	MAY 2013	SCALE: NA	HORIZ. VERT. NA
EXPIRES 06-30-14		9/15/14	
SHEET DT2		6 OF 19 SHEETS	
DRAWING NO. 1074994-2		H#53326	