

**A** TYPICAL 47' STREET SECTION  
INYO AVENUE  
N.T.S.

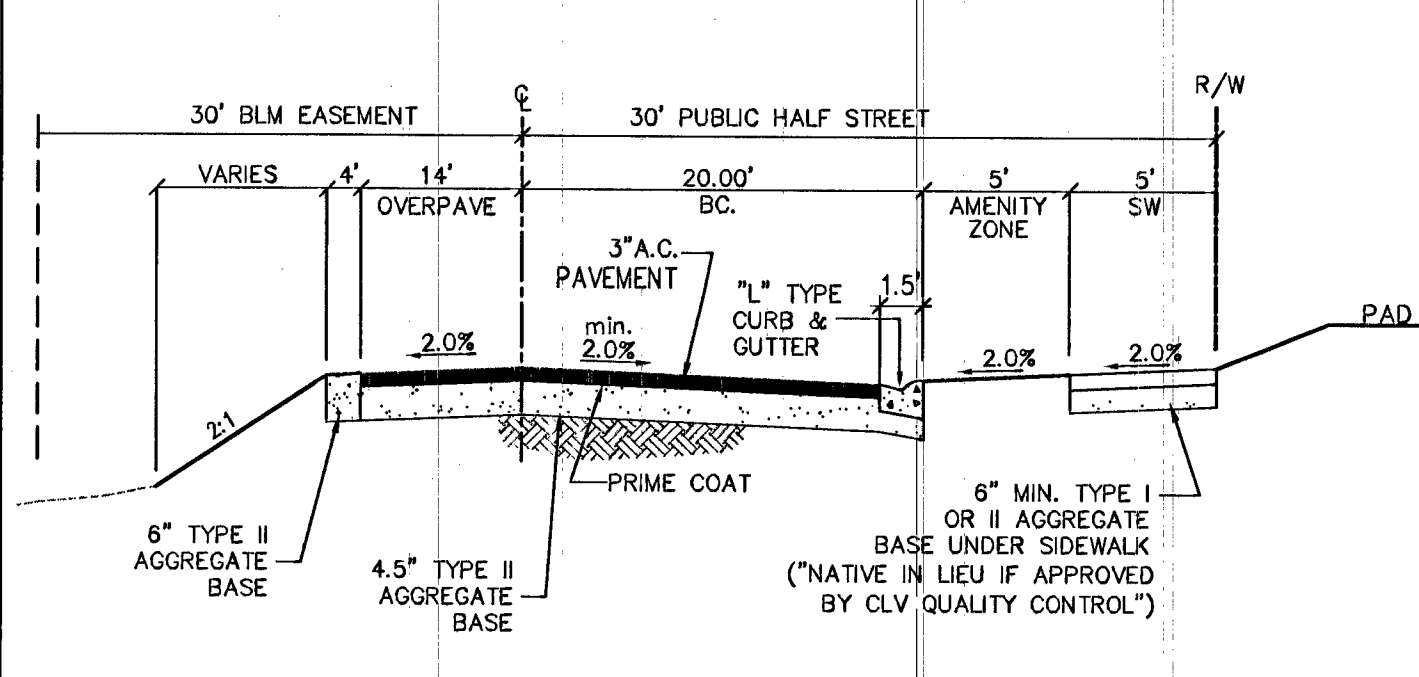

**B** TYPICAL 30' HALF STREET SECTION  
CONQUISTADOR STREET  
N.T.S.

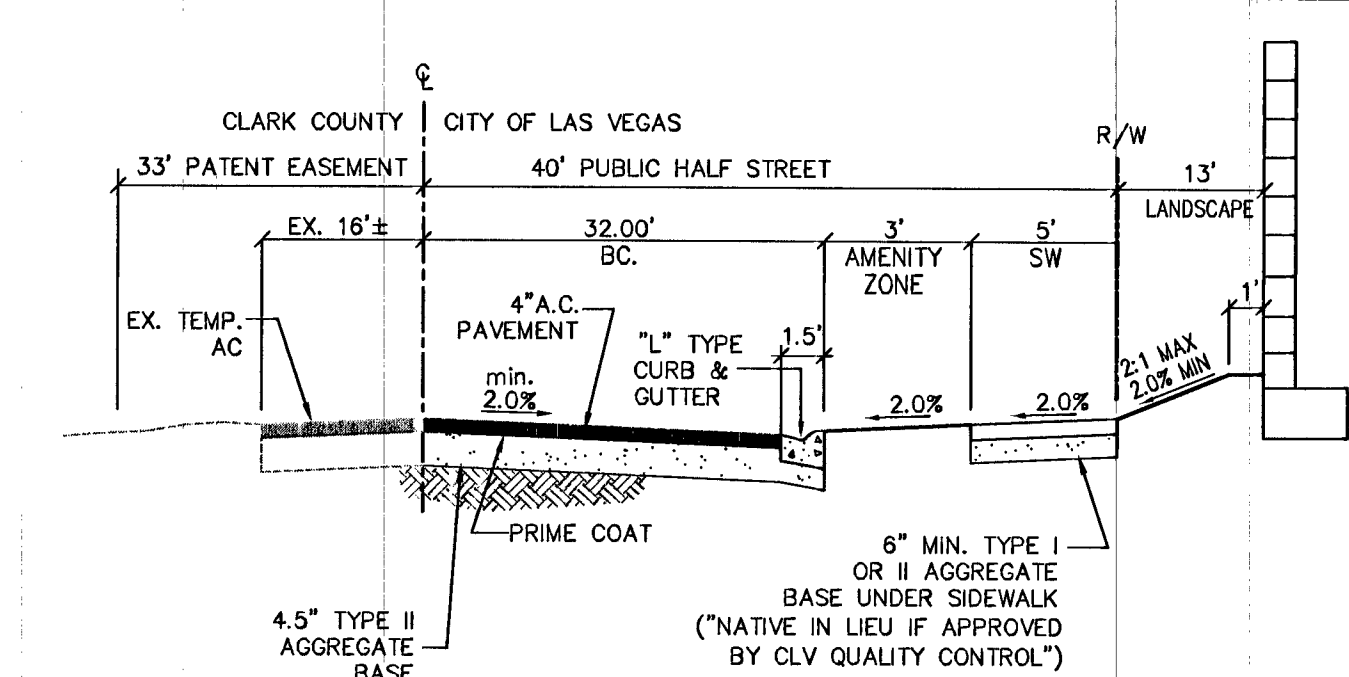

**C** TYPICAL 40' HALF STREET SECTION  
DEER SPRINGS WAY  
N.T.S.

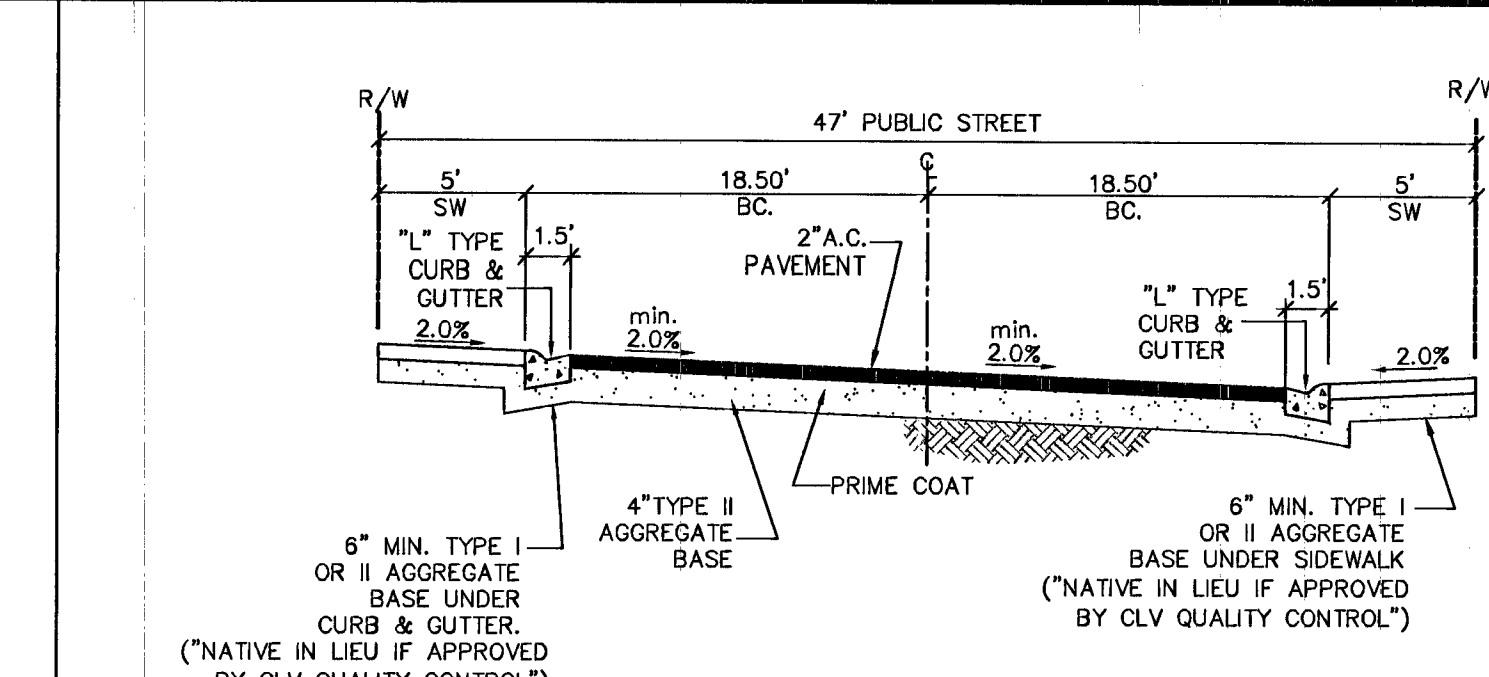

**D** 47' STREET SECTION  
BRISTLE FALLS STREET  
N.T.S.

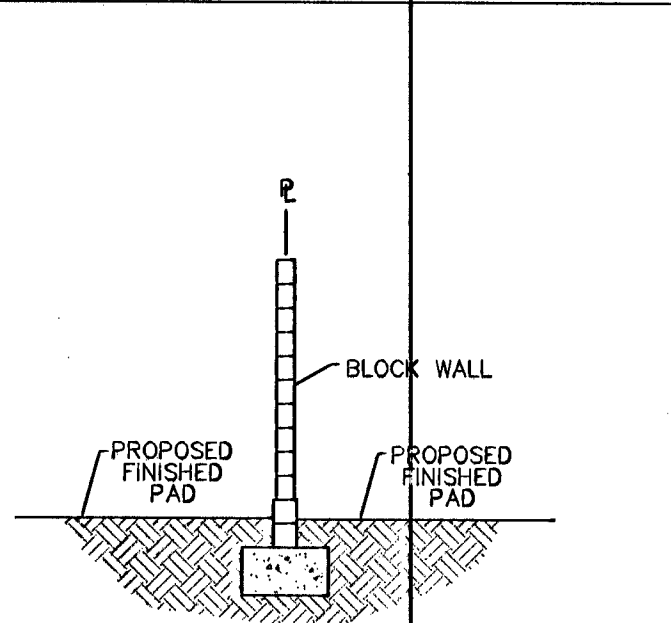

**E** INTERIOR WALL SECTION  
N.T.S.

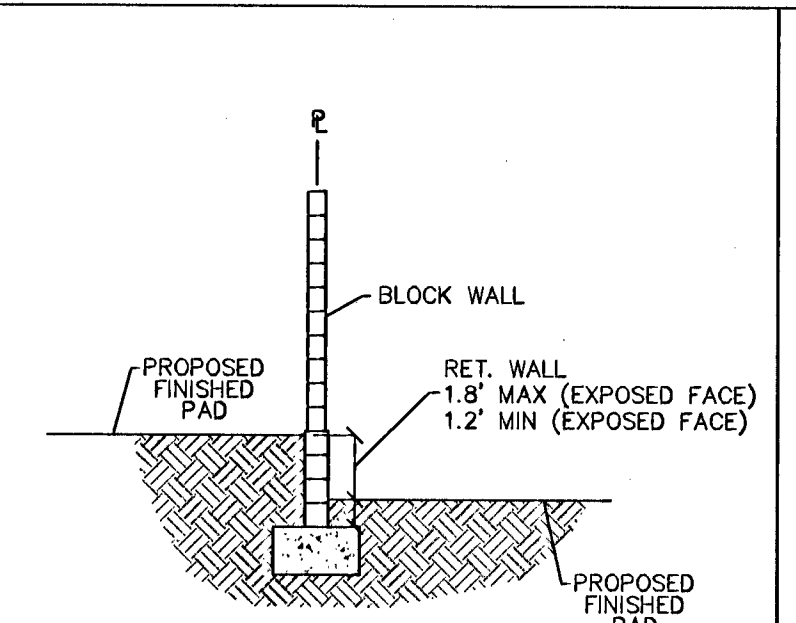

**F** INTERIOR WALL SECTION  
N.T.S.

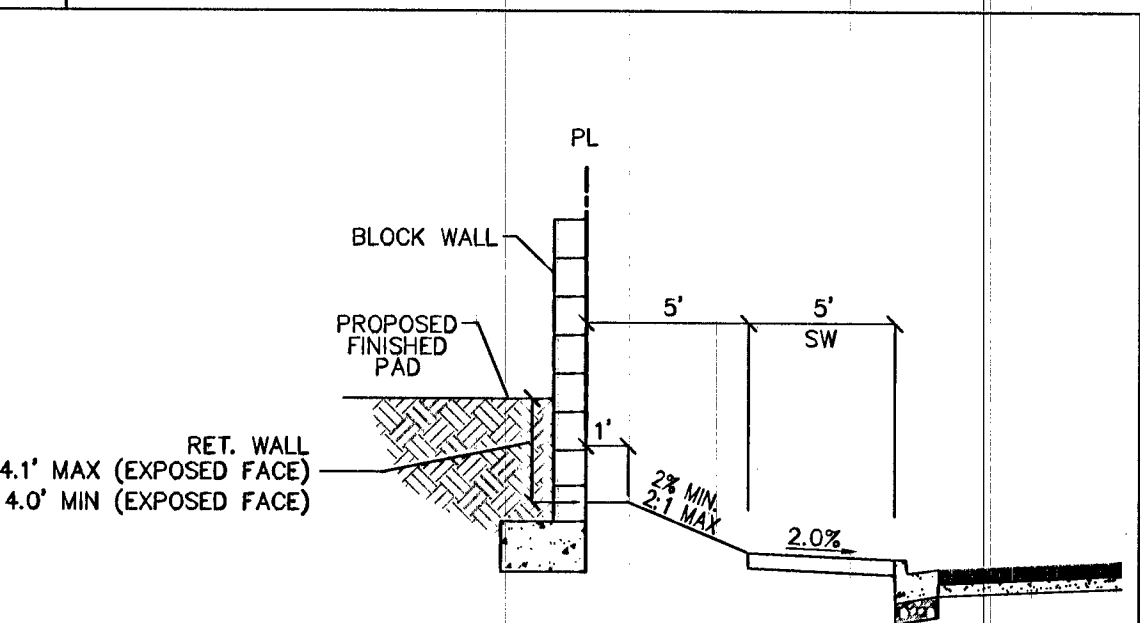

**G** CORNER LOT WALL SECTION  
N.T.S.

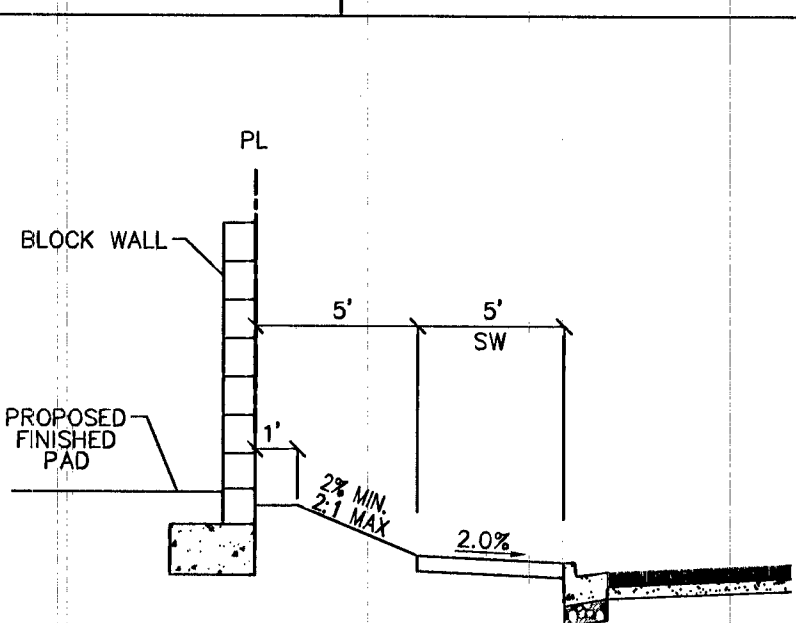

**H** CORNER LOT WALL SECTION  
N.T.S.

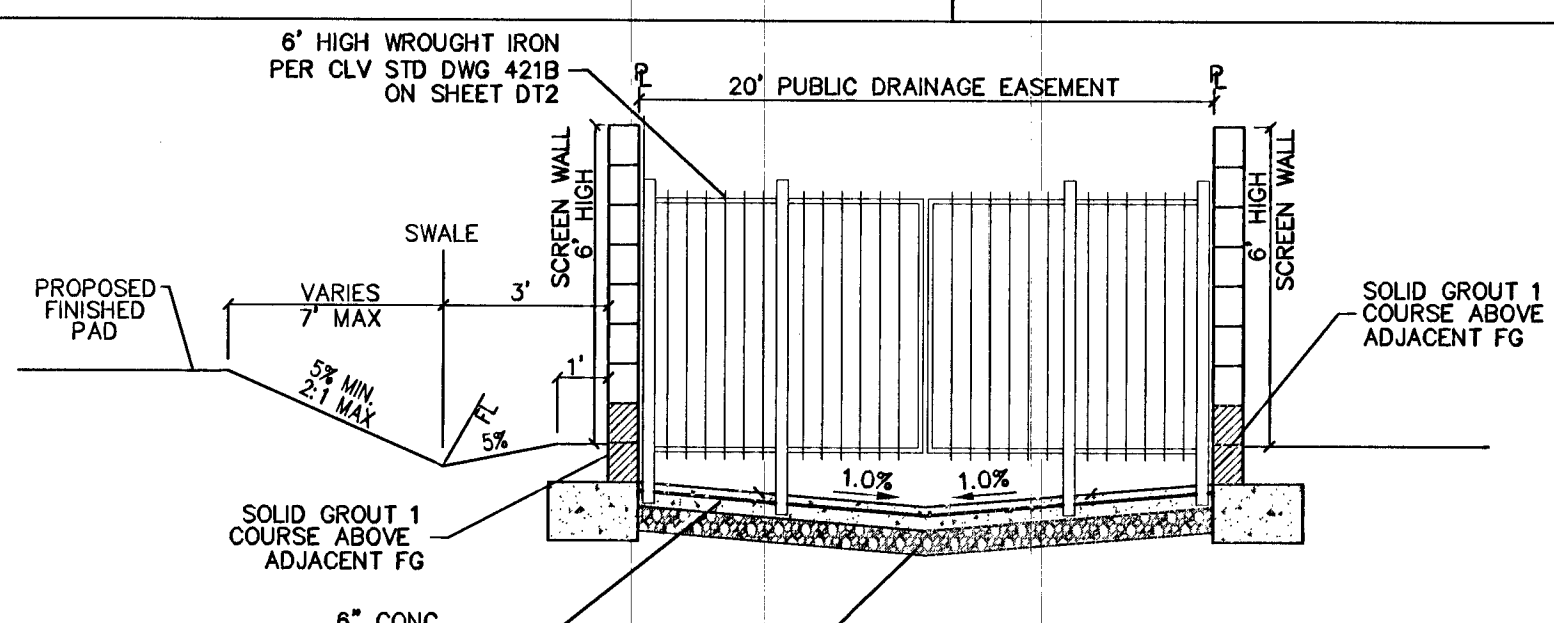

**I** 20' PUBLIC DRAINAGE EASEMENT  
N.T.S. EASEMENT TO BE PRIVATELY MAINTAINED BY HOA

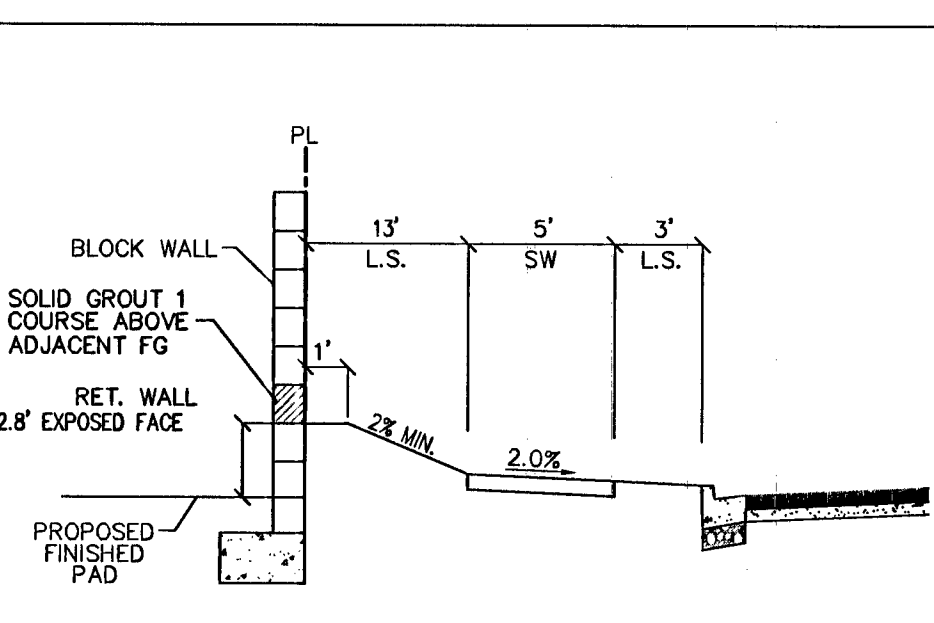

**J** CORNER LOT WALL SECTION  
N.T.S.

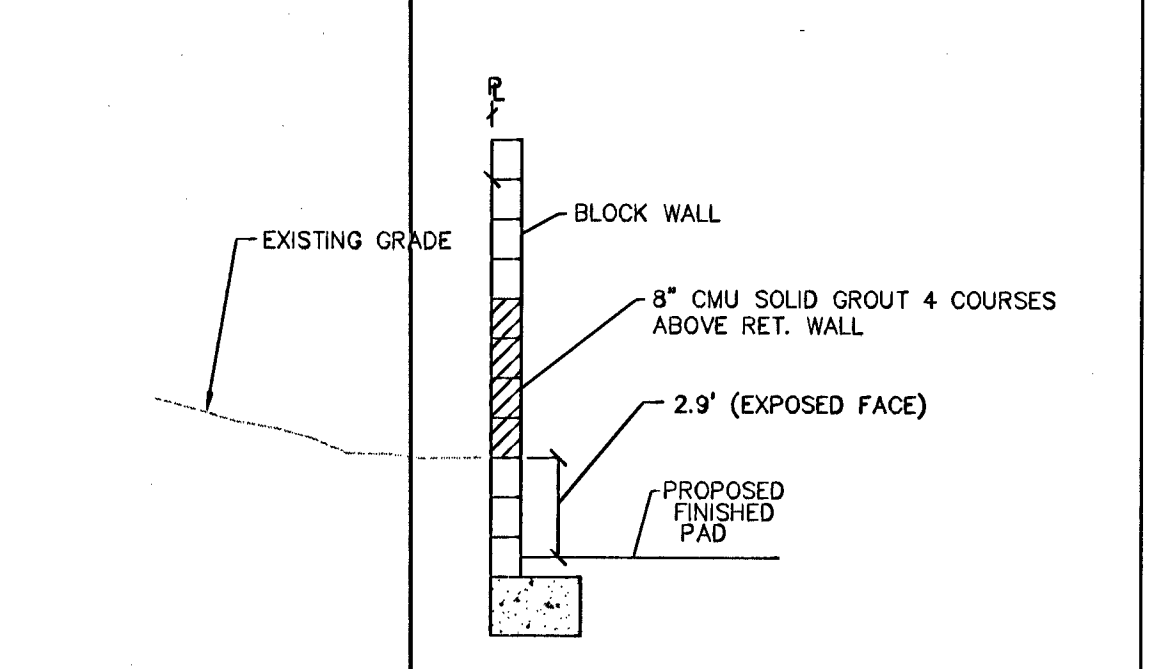

**K** OFFSITE DRAINAGE SWALE  
N.T.S.

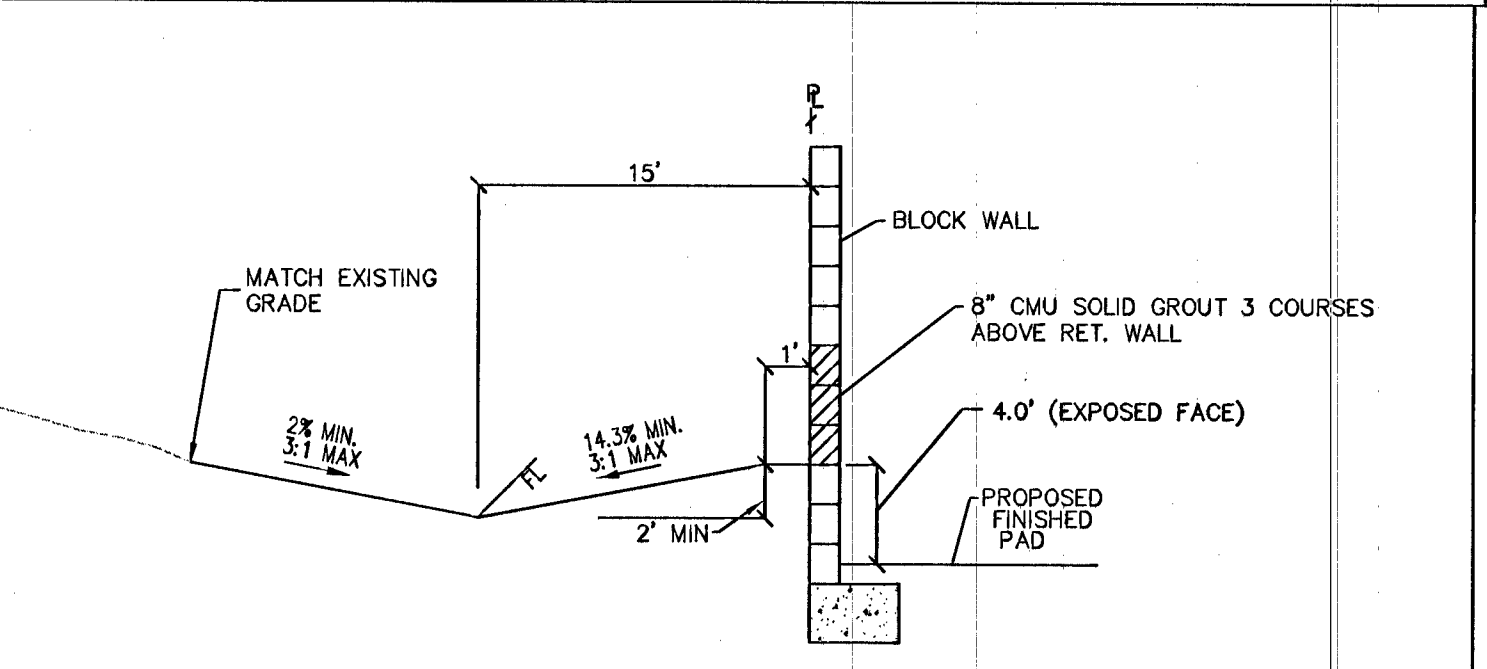

**L** OFFSITE DRAINAGE SWALE  
N.T.S.

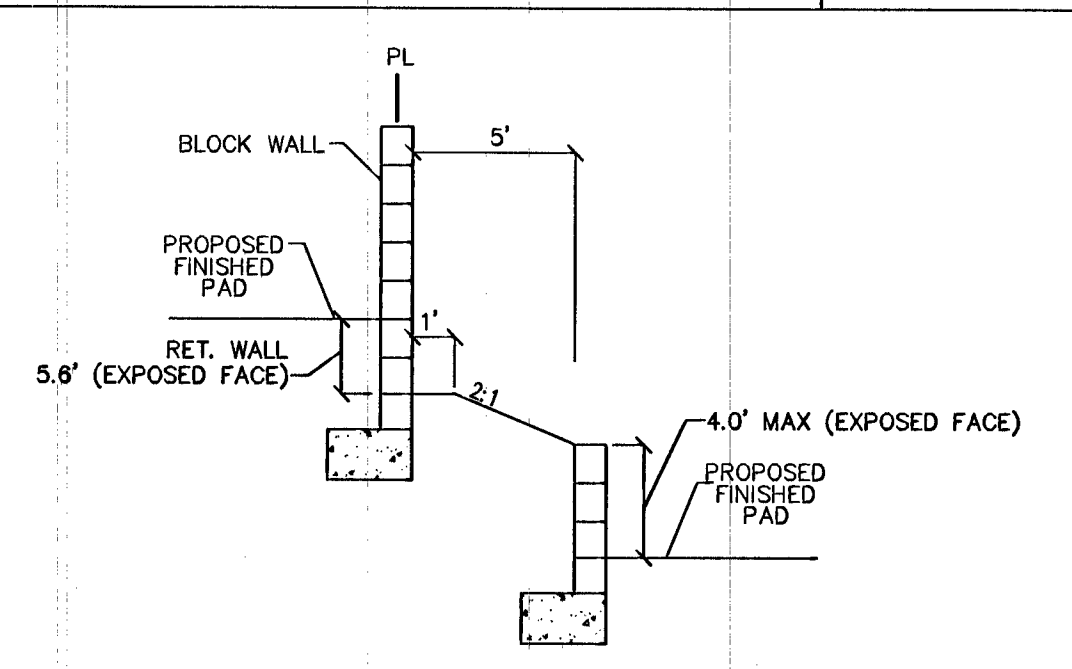

**M** REAR LOT WALL SECTION  
N.T.S.

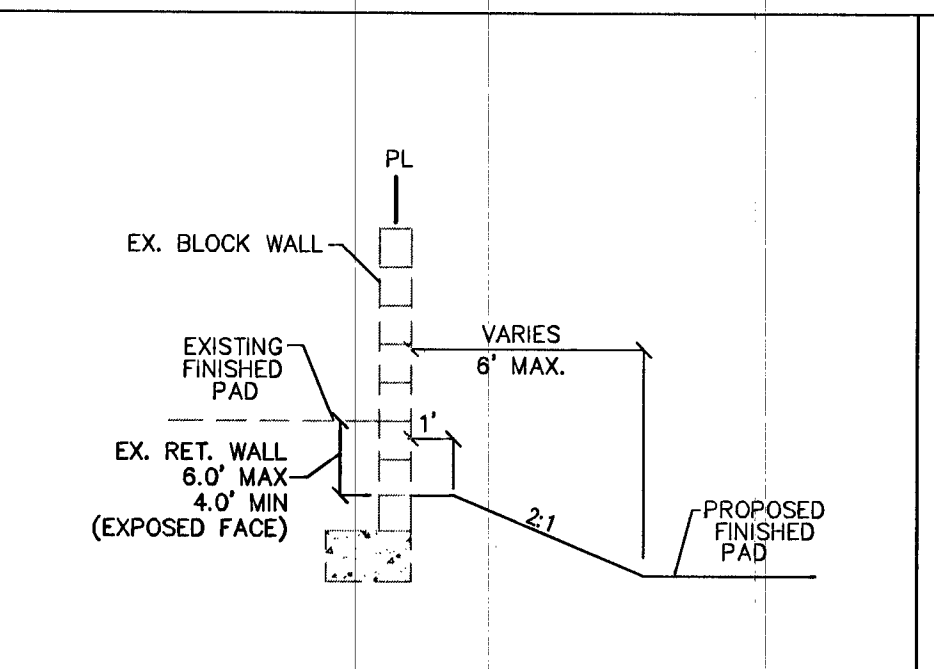

**N** REAR LOT WALL SECTION  
N.T.S.

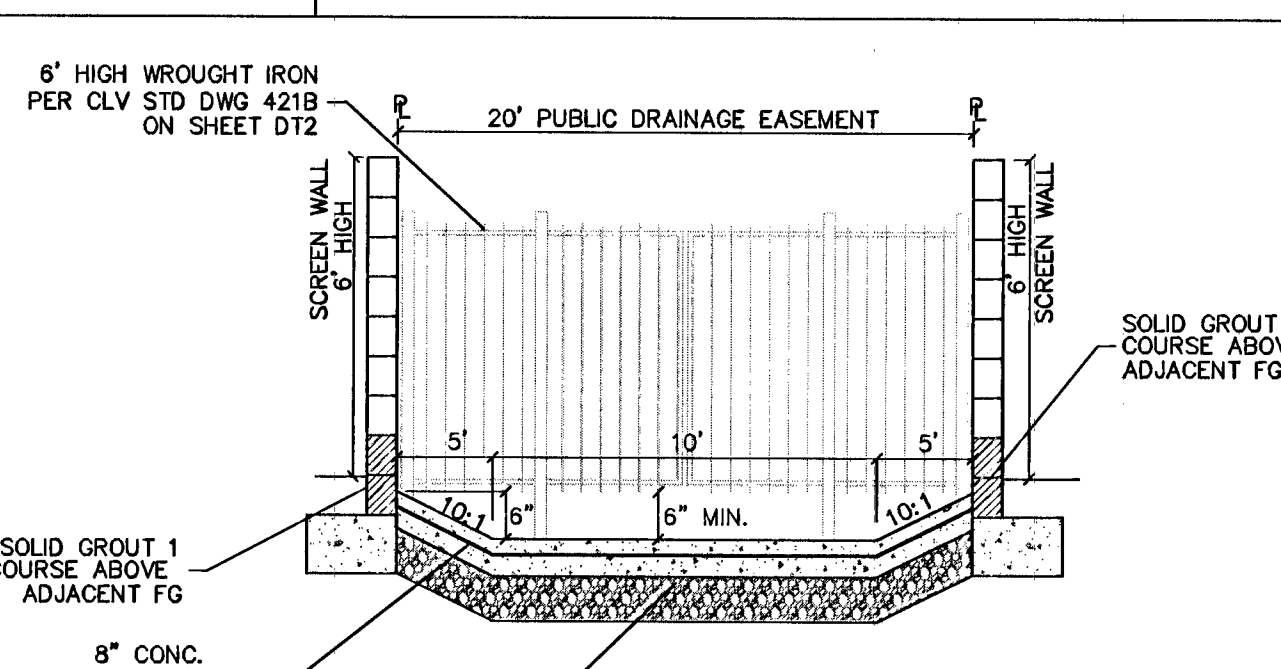

**O** 20' PUBLIC DRAINAGE EASEMENT  
N.T.S. EASEMENT TO BE PRIVATELY MAINTAINED BY HOA

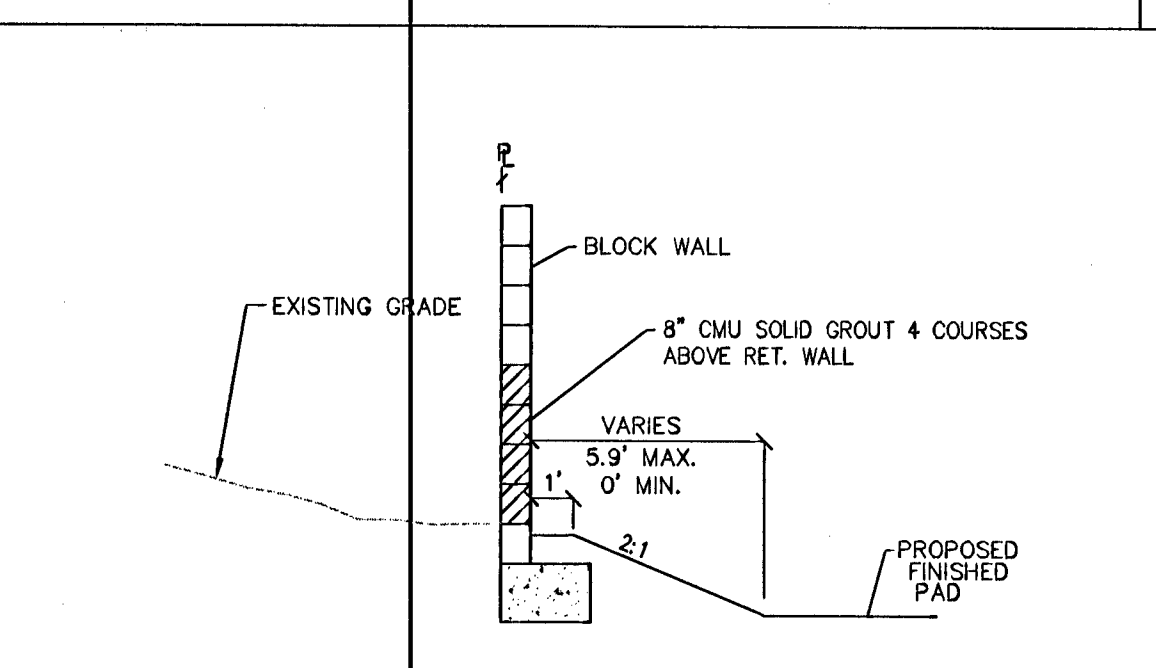

**P** OFFSITE DRAINAGE SWALE  
N.T.S.

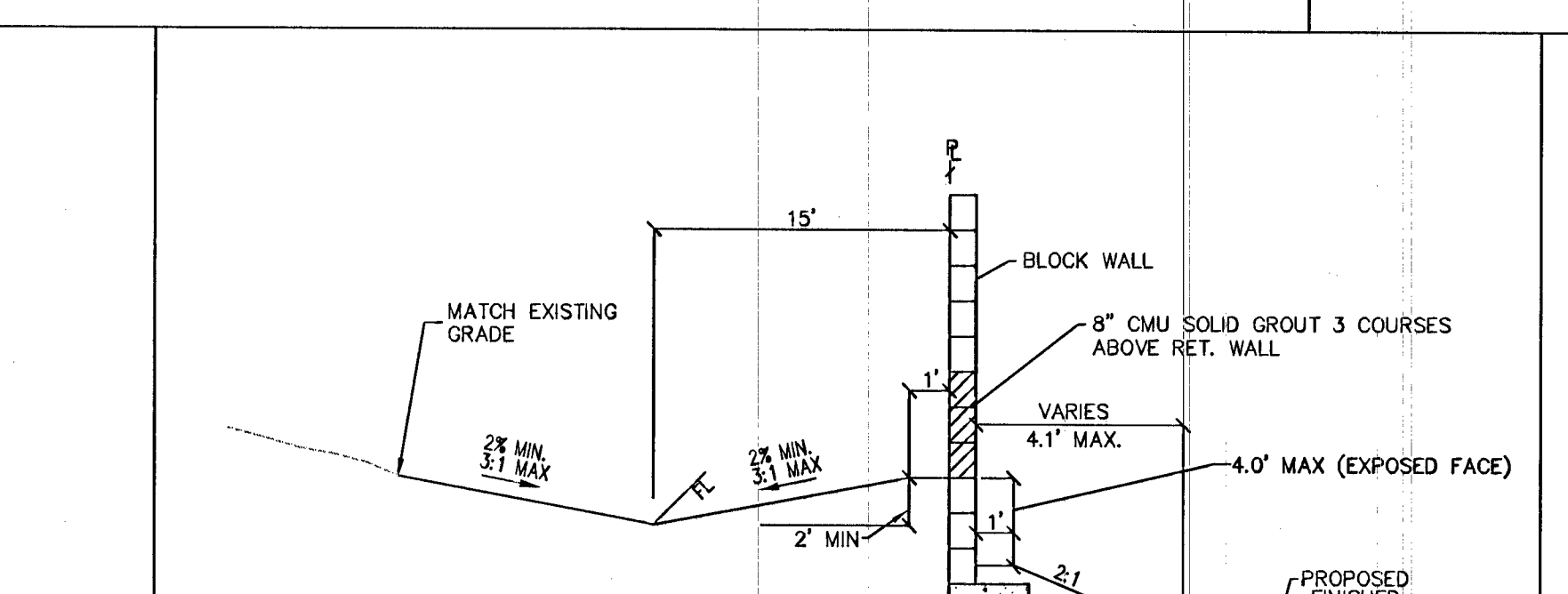

**Q** OFFSITE DRAINAGE SWALE  
N.T.S.

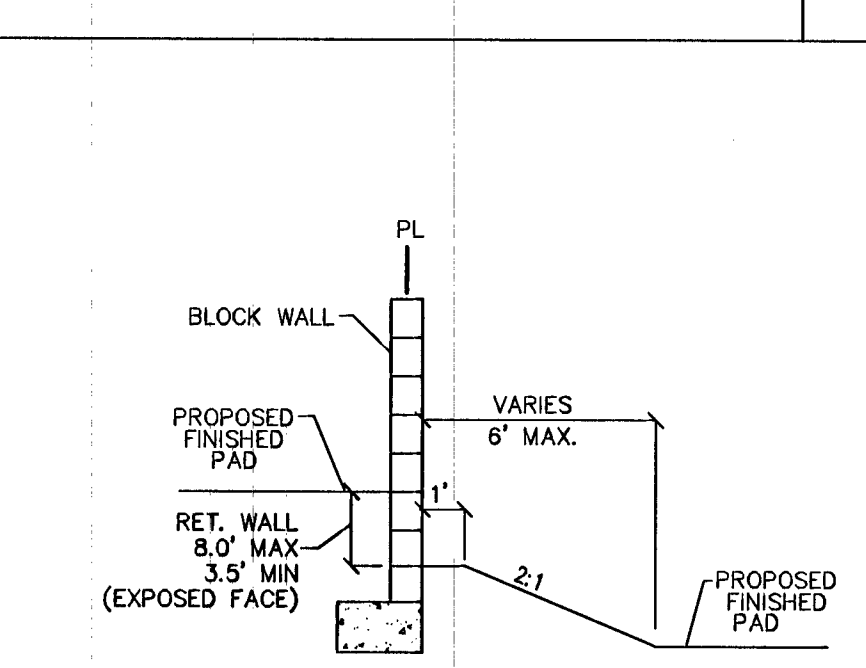

**R** REAR LOT WALL SECTION  
N.T.S.

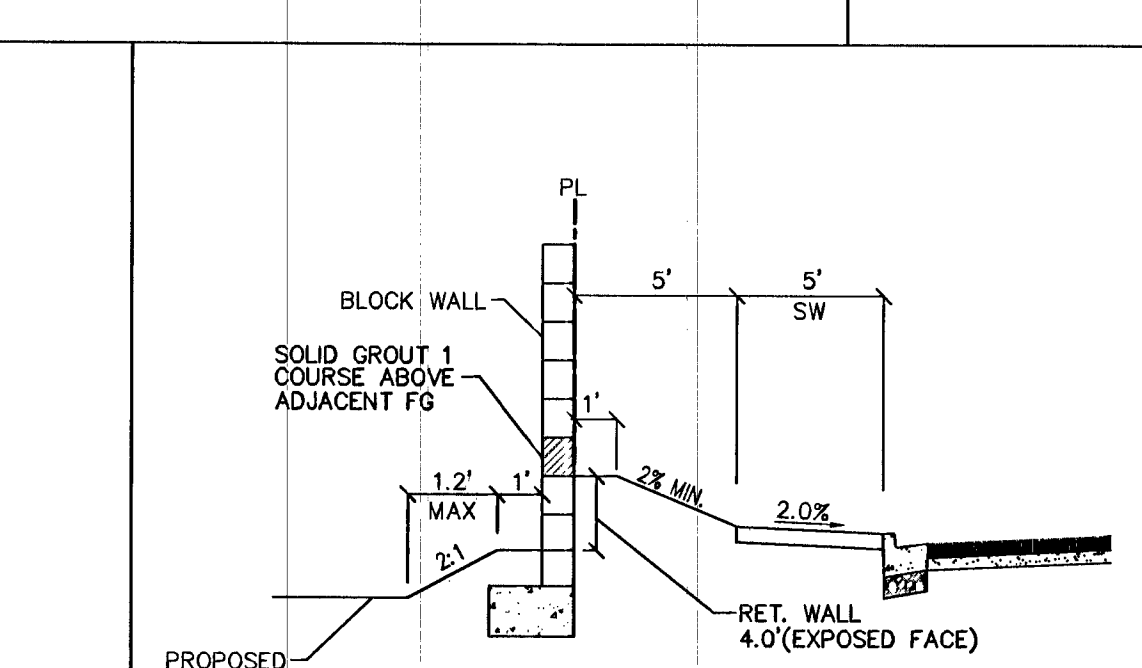

**S** CORNER LOT WALL SECTION  
N.T.S.

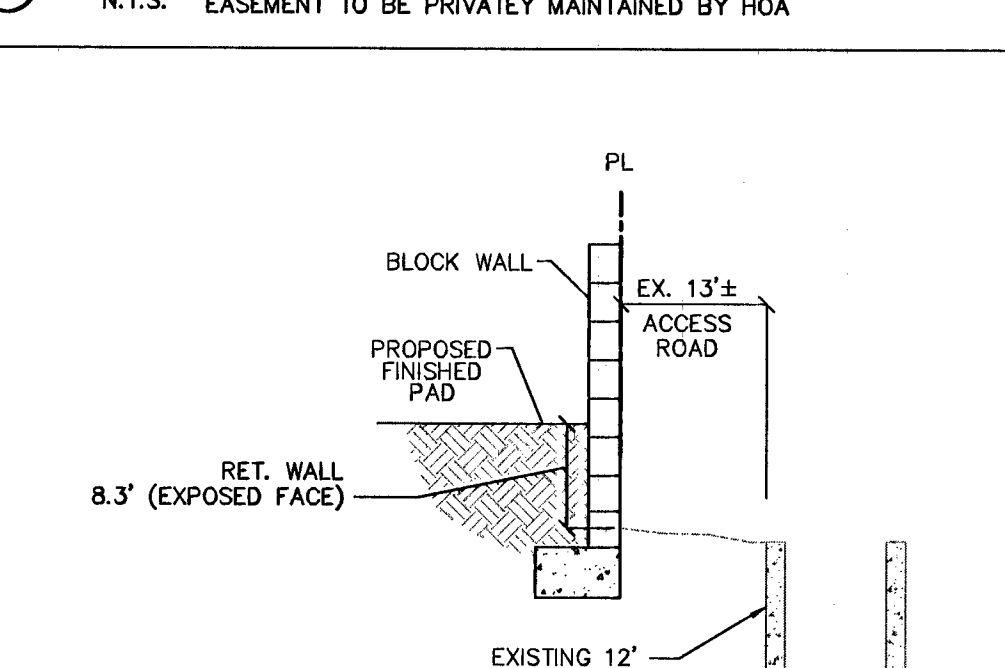

**T** SOUTH PERIMETER WALL SECTION  
N.T.S.

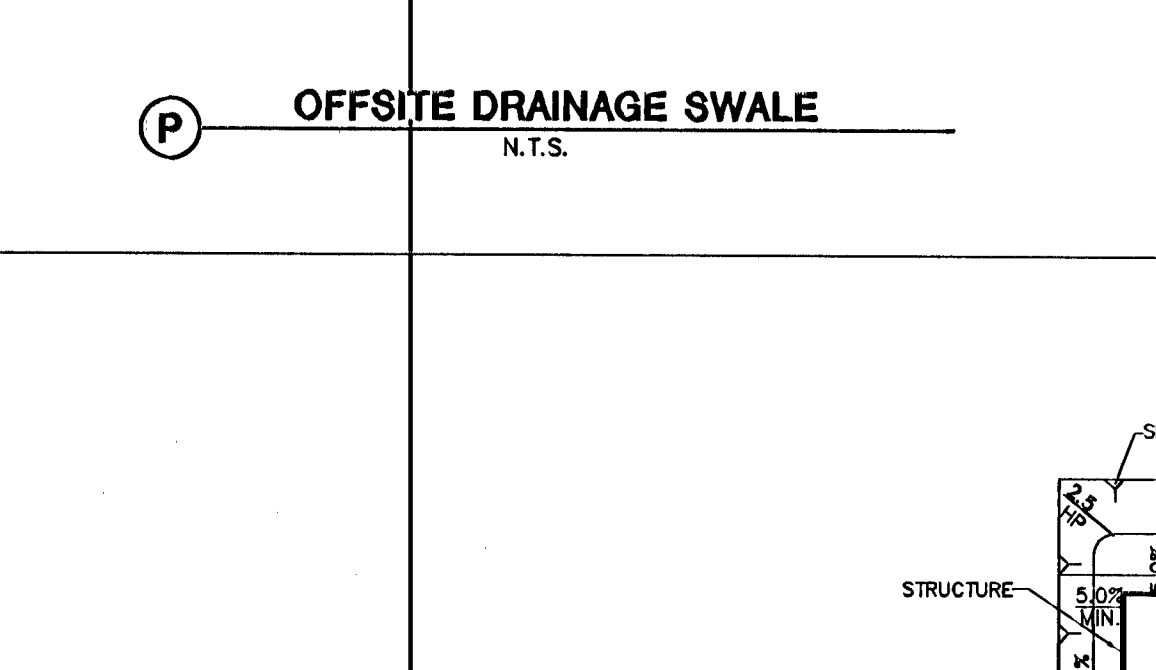

**TYPICAL LOT GRADING PLAN**  
N.T.S.

- NOTES:**
1. GRADING TO BE IN COMPLIANCE WITH 2009 INTERNATIONAL BUILDING CODE & AMENDMENTS, LATEST EDITION.
  2. STRUCTURAL PAD SHALL BE 3' BEYOND BLDG. SETBACK, SEE TYPICAL GRADING SECTION.
  3. REAR LOT CORNER GRADES ARE EQUAL TO PAD GRADES UNLESS SHOWN OTHERWISE.
  4. MINIMUM SIDEYARD X-SLOPE SHALL BE 5%.
  5. MAXIMUM REAR YARD SLOPE IS 2:1 AS SHOWN, EXCEPT THAT WITHIN 15' OF THE HOUSE, THE MAXIMUM SLOPE IS 12:1.
  6. ELEVATIONS SHOWN HERE ON WITHIN LANDSCAPED AREAS ARE 30 FEET BELOW FINISH GRADES TO ALLOW FOR THE ADDITION OF LANDSCAPING MATERIALS ATOP THESE ROUGH GRADES.
  7. MAXIMUM DRIVEWAY SLOPE NOT TO EXCEED 12.5%.

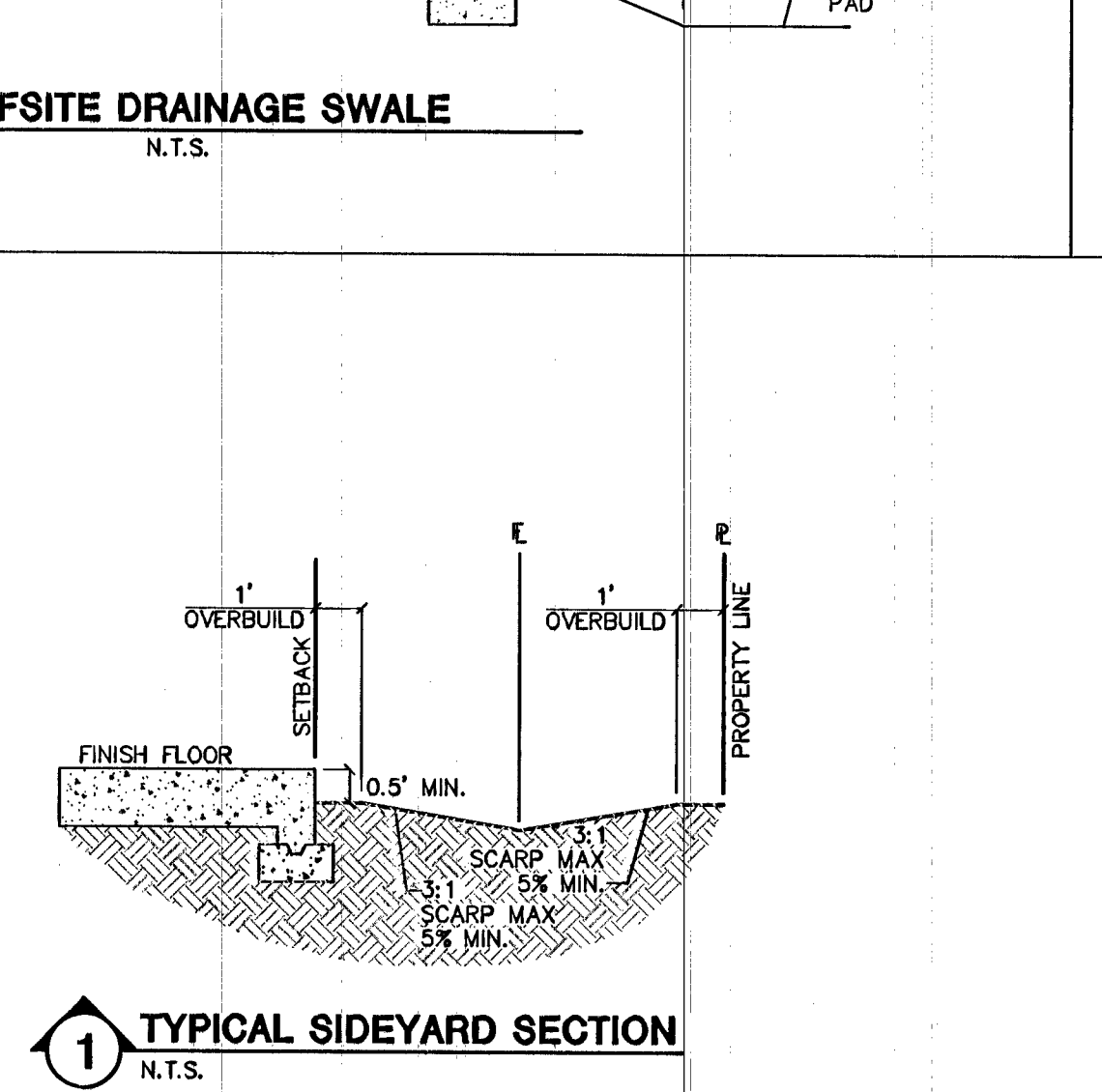

**1** TYPICAL SIDEYARD SECTION  
N.T.S.

**CURVE TABLE**

CURVE	RADIUS	DELTA	LENGTH	TANGENT
C31	20.00'	44°57'53"	15.70'	8.28'
C35	20.00'	43°53'21"	15.32'	8.06'
C36	15.00'	41°21'16"	10.83'	5.66'
C37	15.00'	48°11'23"	12.62'	6.71'
C41	15.00'	42°15'59"	11.07'	5.80'
C42	15.00'	41°21'16"	10.83'	5.66'
C47	45.50'	86°17'25"	68.53'	42.65'
C48	14.50'	74°32'02"	18.86'	11.03'
C49	44.00'	4°57'12"	3.80'	1.90'
C50	45.50'	46°53'26"	37.24'	19.73'

**CURVE TABLE**

CURVE	RADIUS	DELTA	LENGTH	TANGENT
C51	45.50'	58°15'52"	46.27'	25.36'
C53	16.00'	41°35'07"	11.61'	6.08'
C57	1892.00'	3°35'28"	118.58'	59.31'
C59	45.50'	131°35'07"	104.50'	101.21'
C60	1838.75'	5°07'43"	164.59'	82.35'
C61	20.00'	49°56'15"	17.43'	9.31'
C69	15.00'	48°11'23"	12.62'	6.71'
C74	15.00'	42°15'59"	11.07'	5.80'
C75	15.00'	48°11'23"	12.62'	6.71'
C78	15.00'	48°11'23"	12.62'	6.71'

**CURVE TABLE**

CURVE	RADIUS	DELTA	LENGTH	TANGENT
C79	15.00'	41°21'16"	10.83'	5.66'
C80	15.00'	42°15'59"	11.07'	5.80'
C81	15.00'	48°11'23"	12.62'	6.71'
C91	15.00'	48°11'23"	12.62'	6.71'
C95	20.00'	69°30'46"	24.26'	13.88'
C96	20.00'	19°56'58"	6.96'	3.52'
C99	45.50'	58°17'44"	46.29'	25.37'

**CITY OF LAS VEGAS**  
2727 SOUTH RAINBOW BOULEVARD  
LAS VEGAS, NEVADA 89146-9148  
PH. (702) 873-7550 FAX (702) 362-2597 WEB WWW.VNVM.COM  
CONSULTING ENGINEERS • PLANNERS • LAND SURVEYORS

**RYLAND HOMES**  
8925 W. RUSSELL ROAD, SUITE 200  
LAS VEGAS, NV 89148  
(702) 366-7550

**GRADING DETAILS**  
**BRISTLE FALLS UNIT 2**

DRAWN BY: EM MAY 2013  
DESIGNED BY: AT  
CHECKED BY: AT  
PROJECT NO.: 7919

EXPIRES 06-30-16  
**AARON M. YAMACHIKA**  
REGISTERED PROFESSIONAL ENGINEER  
STATE OF NEVADA  
LICENSE NO. 15079

SHEET **DT1**  
5 OF 19 SHEETS  
DRAWING NO. 1074994-2

HTE 14-17769  
H#53326