

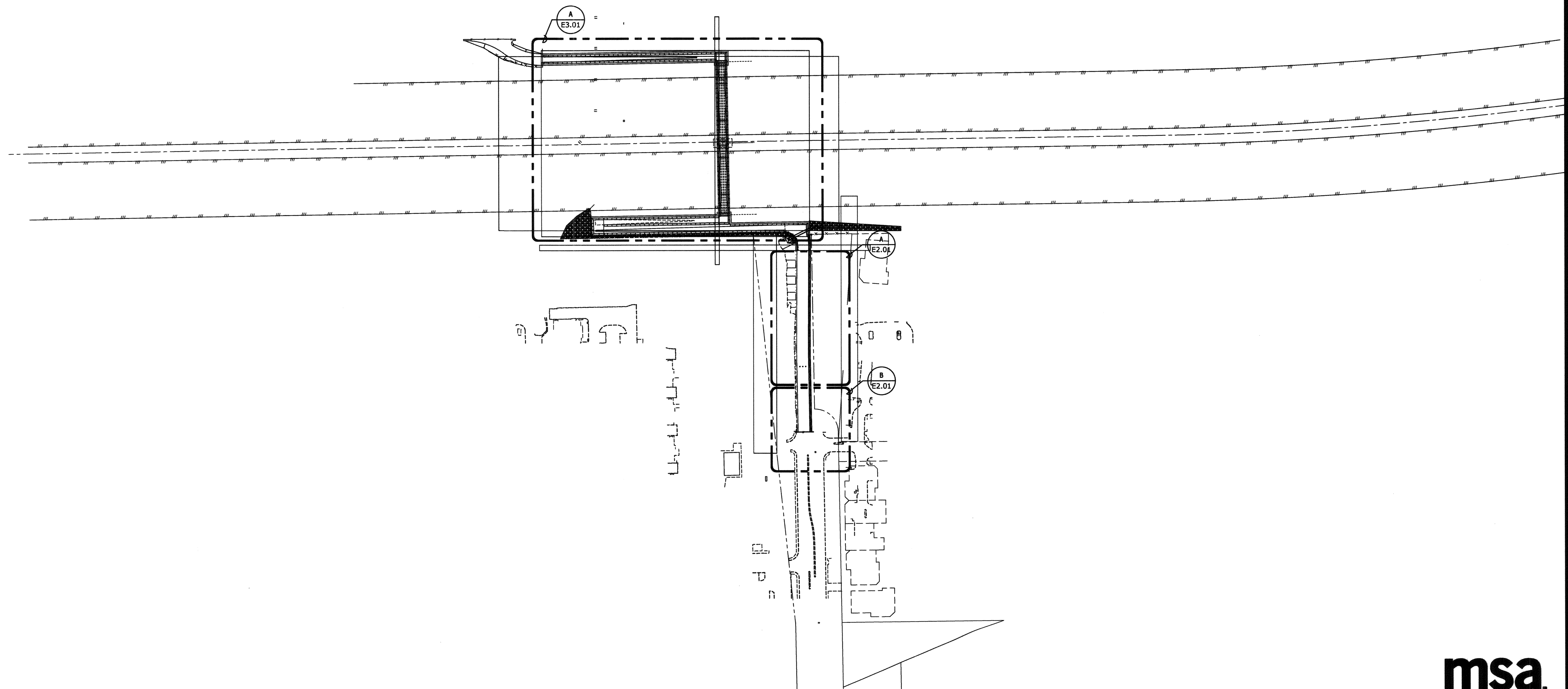

B
E1.00 ELEVATION PLAN
1" = 20'-0"

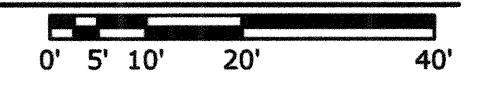

A
E1.00 ELECTRICAL OVERVIEW PLAN
1" = 90'-0"

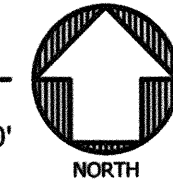
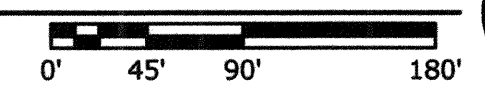

NO.	DATE	SHEET	REVISIONS



 PREPARED BY
**DEPARTMENT OF
 PUBLIC WORKS
 CAPITAL PROJECT MGMT**



**FOGEMEYER
 DESIGN GROUP**
 6900 Smoke Ranch Road - Suite 110
 Las Vegas, Nevada 89128 - (702) 265-6100

PREPARED FOR CITY OF LAS VEGAS	BID# 17-48638	DESIGNED BY: PE
HR 49638	DATE: JANUARY 2018	DRAWN BY: MSA
SUBMITTAL STAGE: 100% FINAL	CHECKED BY: PE	

TITLE
**CIMARRON PEDESTRIAN BRIDGE
 AT SUMMERLIN PARKWAY**

SHEET
ELECTRICAL OVERVIEW PLAN

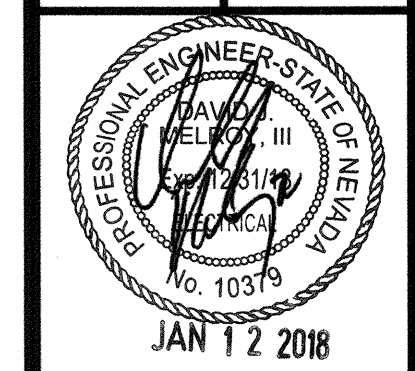

SHEET
E1.00
 84 OF 86

DRAWING NO.
676-22

msa.
 ENGINEERING CONSULTANTS
 370 E Windmill Lane, Suite 100
 Las Vegas, NV 89123
 702.896.1100
 msa-ec.com
 MSA#L16032

FEDERAL PROJECT NUMBER: CM-0003(180)