

JOB NO. 499510

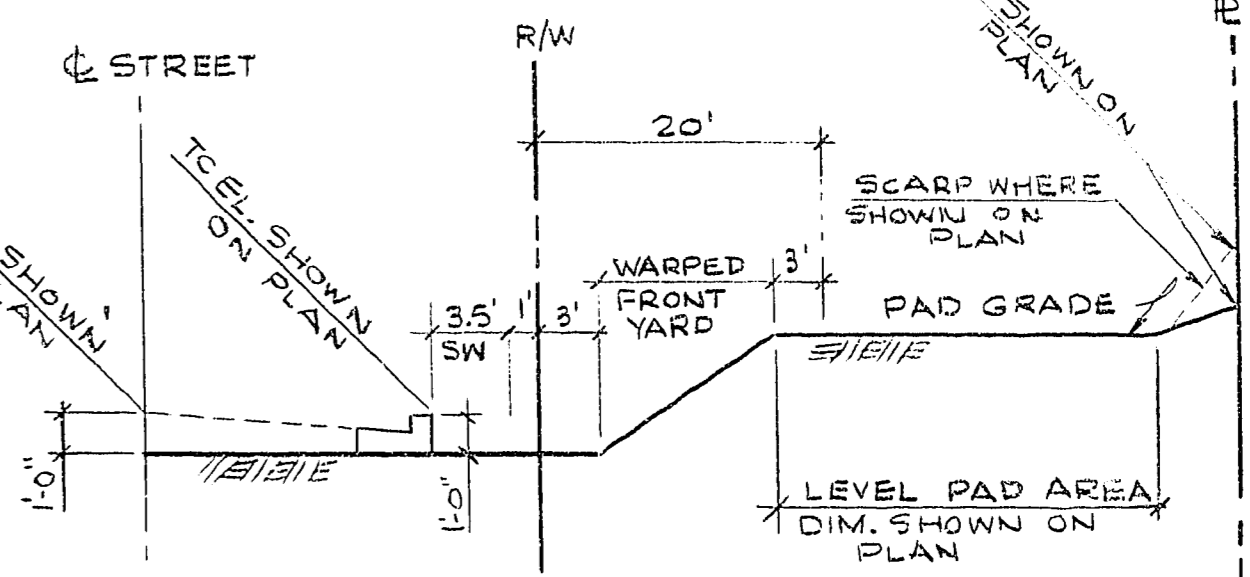

TYPICAL ROUGH GRADING

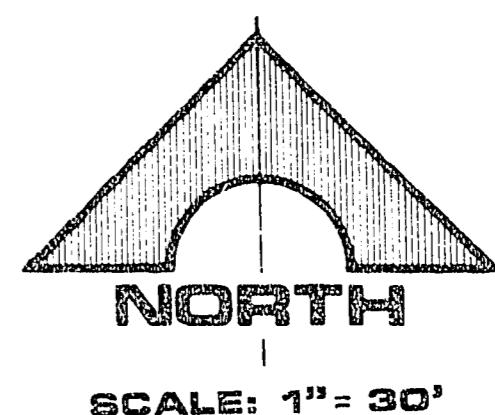
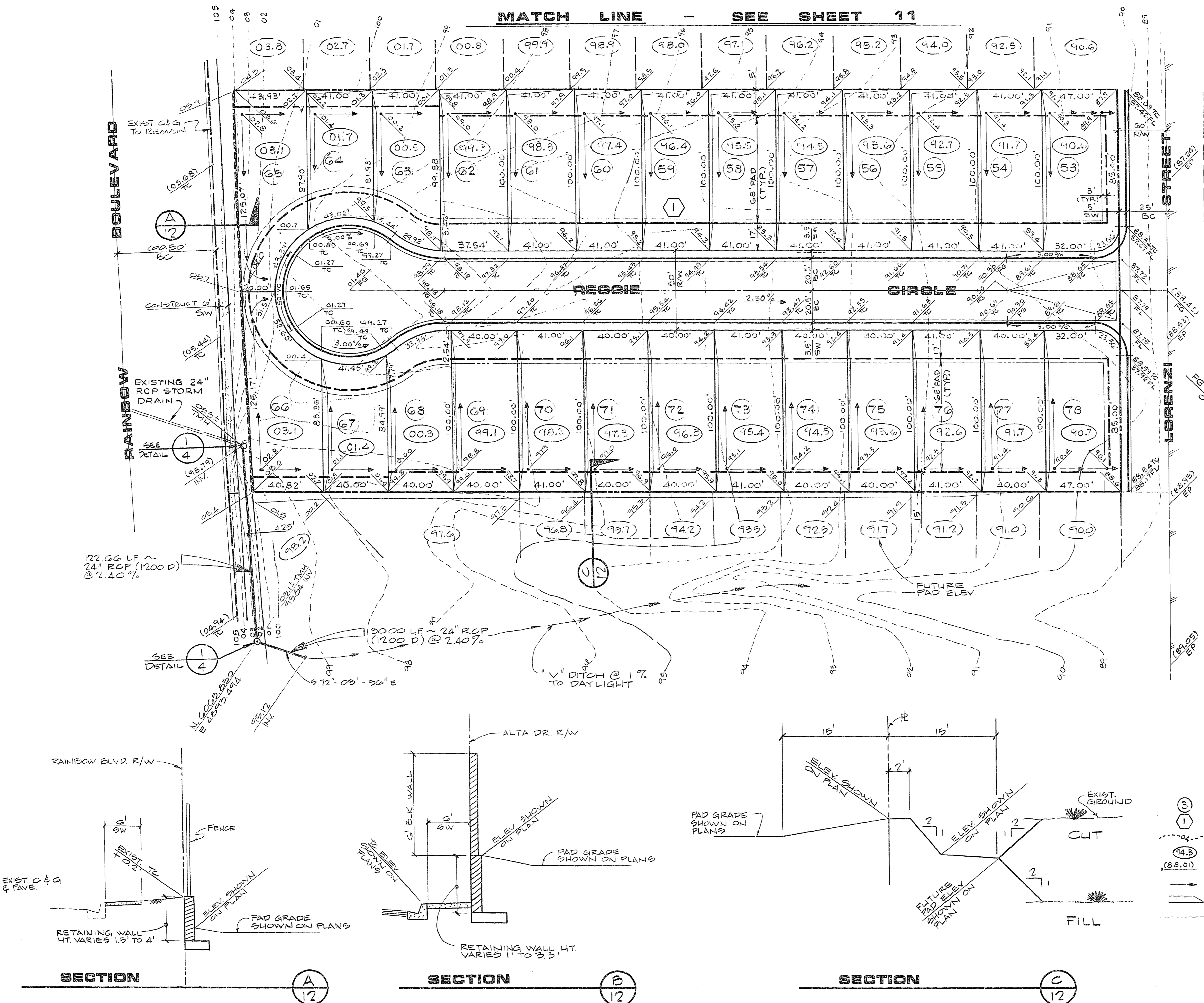
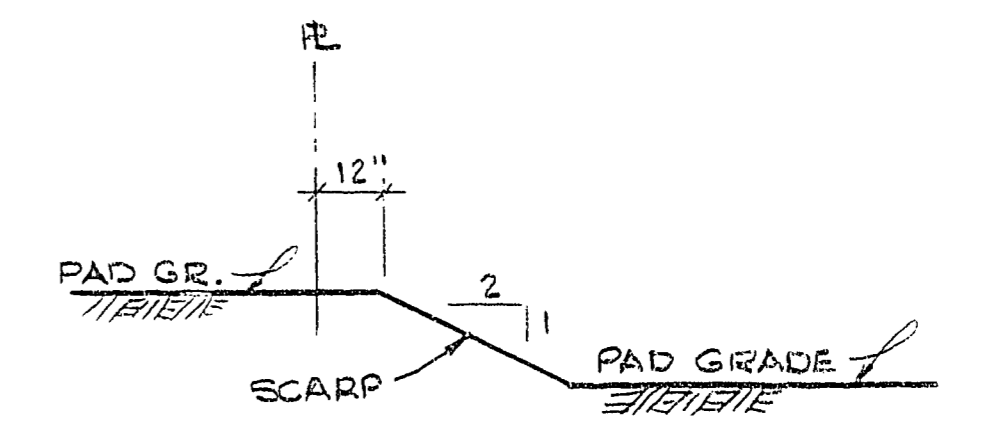

TYPICAL SIDE & REAR YARD SCARP SECTION

LEGEND

- (3) LOT NUMBER
 - (1) BLOCK NUMBER
 - EXISTING CONTOUR
 - (94.3) PAD GRADE
 - (88.01) EXISTING ELEVATION
 - - - DITCH OR SWALE
 - 2:1 SCARP
 - SETBACK LINE:
 - FG FINISH GRADE
 - TC TOP OF CURB
 - FL FLOW LINE
 - EP EDGE OF PAVEMENT
 - PAD LIMIT
 - 6' BLOCK WALL
 - RETAINING WALL W/6' BLOCK WALL OR FENCE
- CORNER LOT SIDE YARD (LOTS 1, 26 & 27) = 15' MINIMUM
 CORNER LOT SIDE YARD (LOTS 52, 53 & 78) = 10' MINIMUM
 FRONT YARD = 10' MINIMUM

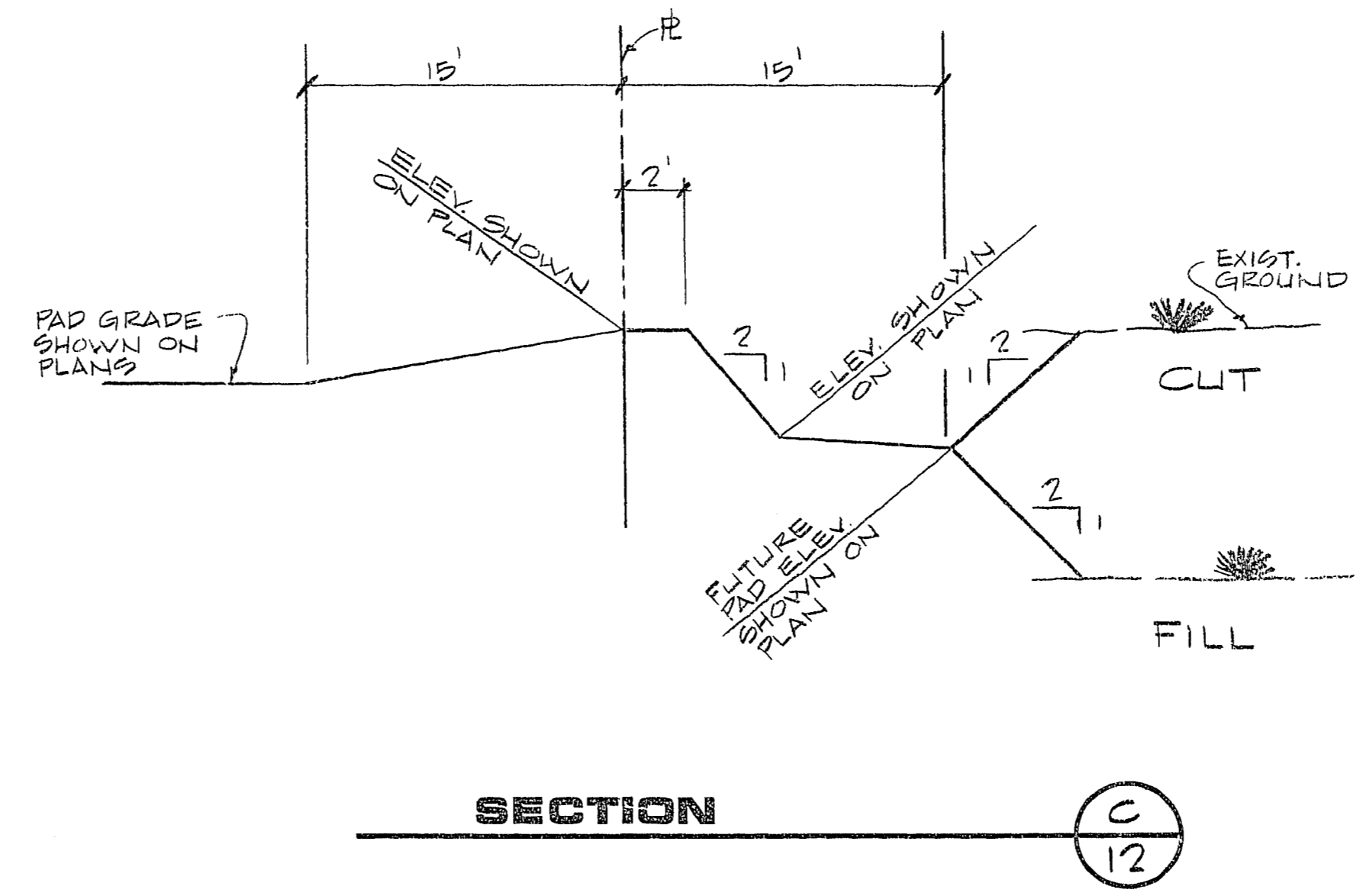
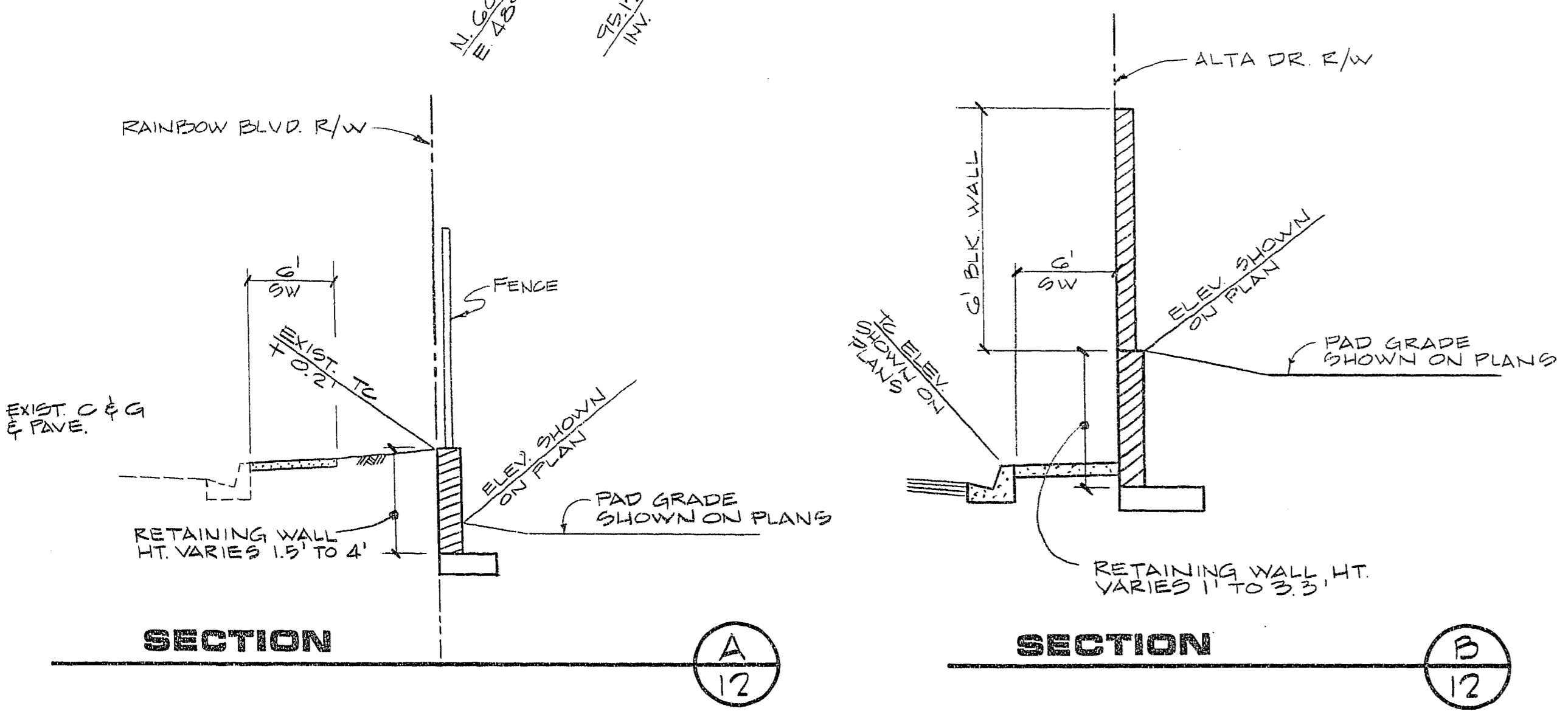

NOTE:
 BLOCK WALLS & RETAINING WALLS DESIGN TO BE APPROVED BY THE C.L.V. DEPT. OF BLDG. & SAFETY PRIOR TO CONST. OR

APPROVAL
 CLV CHIEF LAND DEVELOPMENT AND FLOOD CONTROL
 DATE 1/22/03

RECOMMENDED	DATE	DESCRIPTION
DAVID P. HUCKLE	11/16/02	5256 R.E. NO. DATE
G. C. WALLACE Consulting Engineers, Inc.		
1100 East Sahara Ave. • Las Vegas, Nevada 89104 • 732-3330		
METROPOLITAN DEVELOPMENT CORPORATION METROPOLITAN'S ALTA MEADOWS UNIT NO. 1		
GRADING PLAN II		
SHEET		12
OF 12 SHEETS		

5/76 DIETRICH-POST 6332B
 29 7 07
 1078-2159