

TYPICAL VALLEY GUTTER DETAILS

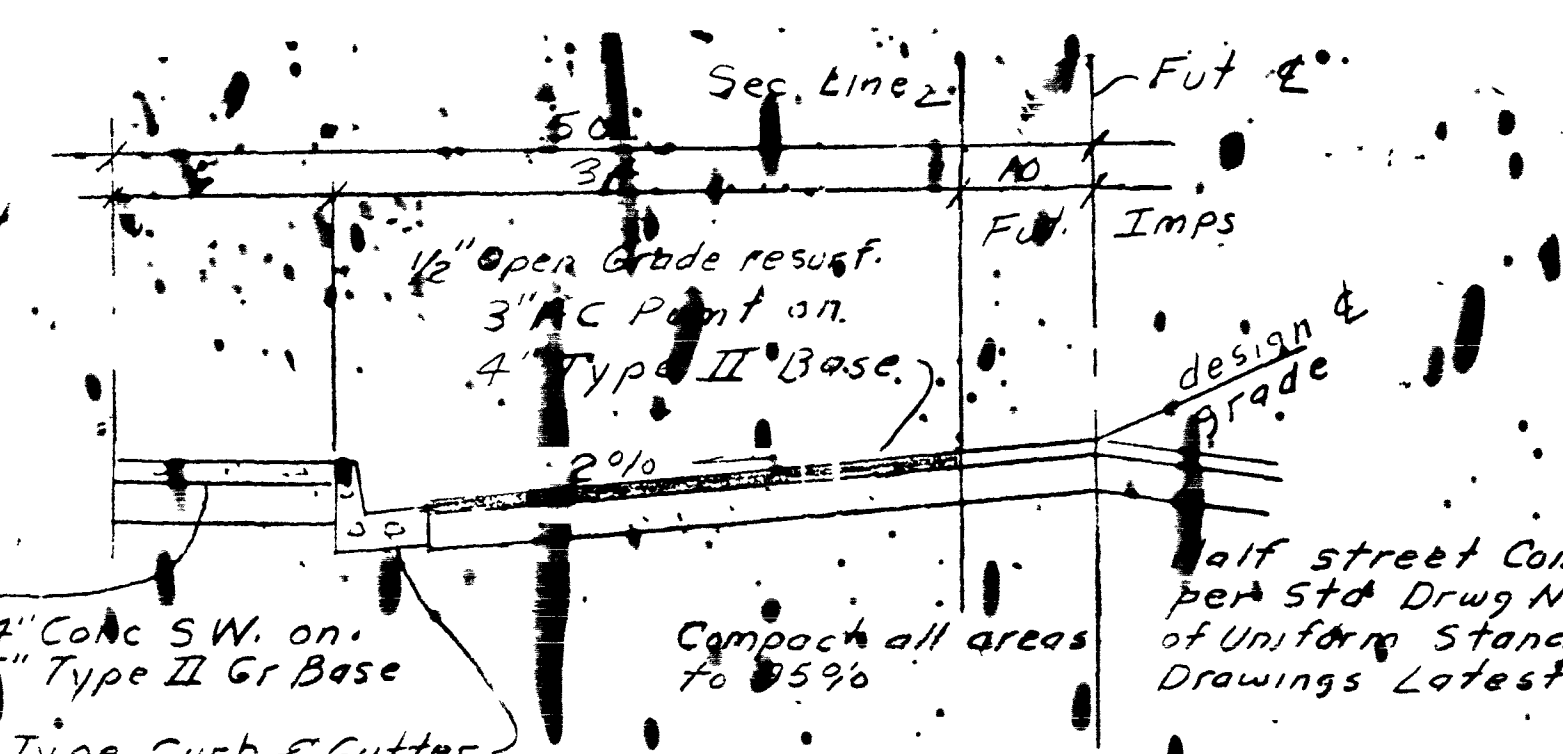

TYPICAL SECTION WESTCLIFF DRIVE

BENCH MARK
 Clark County Bench Mark No
 C 00 SW 33 Nevada Power Co Brass
 Cap SW Cor Sec 33 T20S R60E
 Elev = 2645.01

NOTE:
 EXPANSION JOINTS REQUIRED,
 MAXIMUM EVERY 300' IN
 EXTRUDED TYPE CURB.

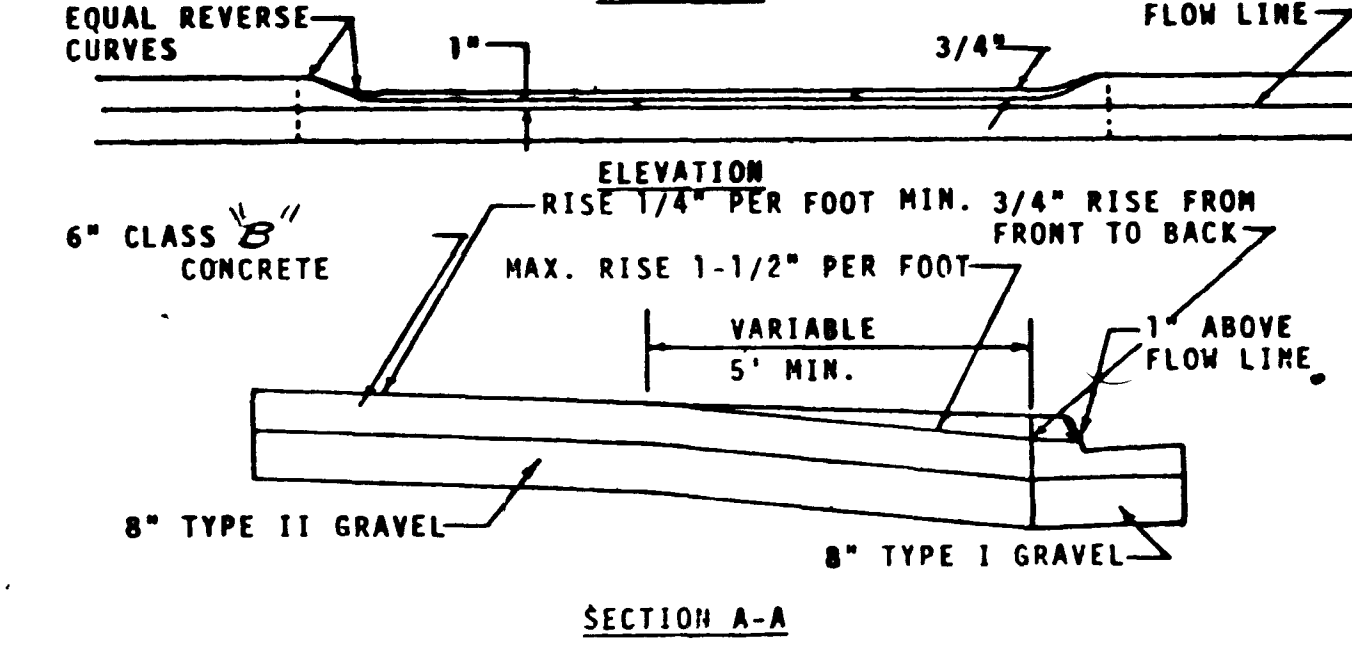
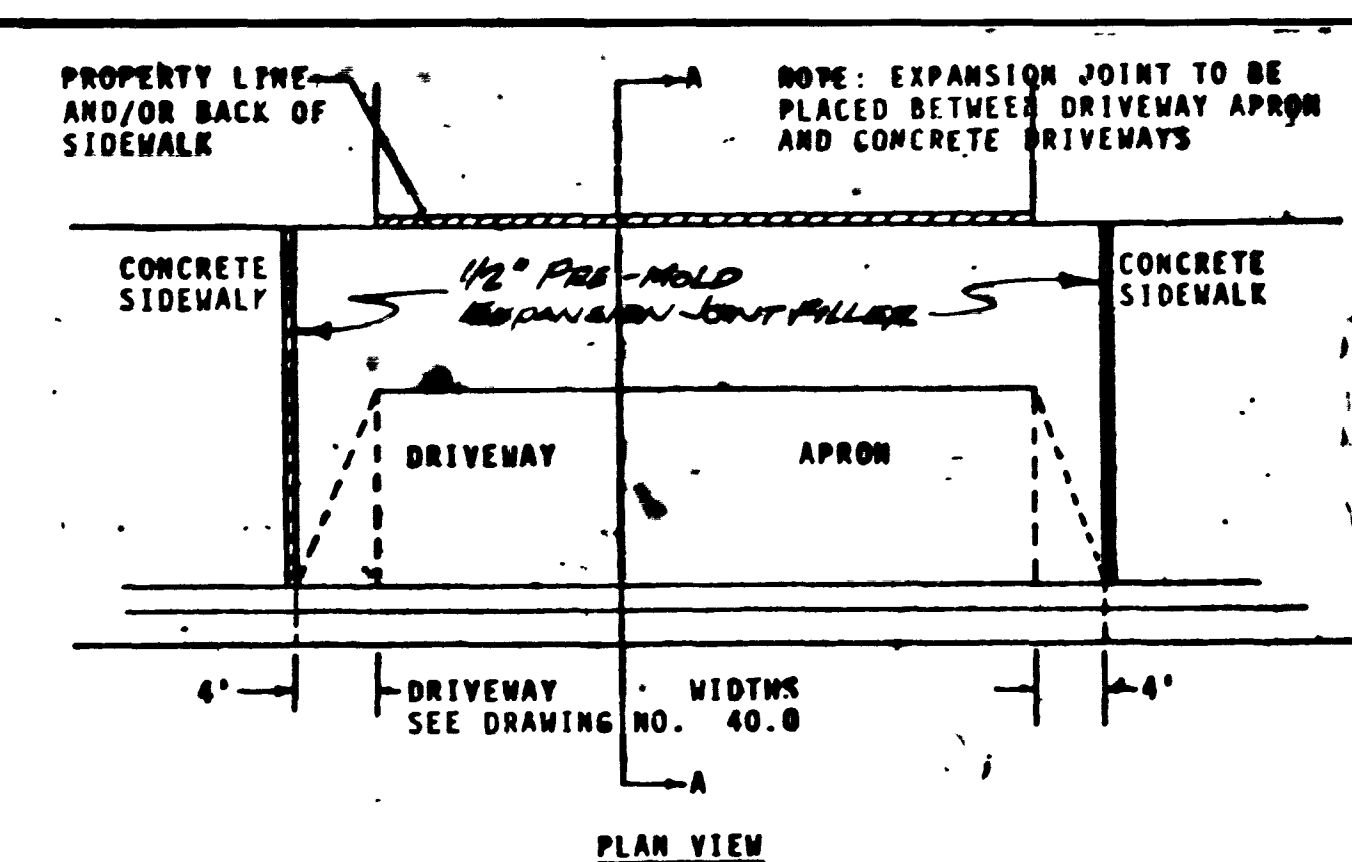

TYPICAL DRIVEWAY DETAIL

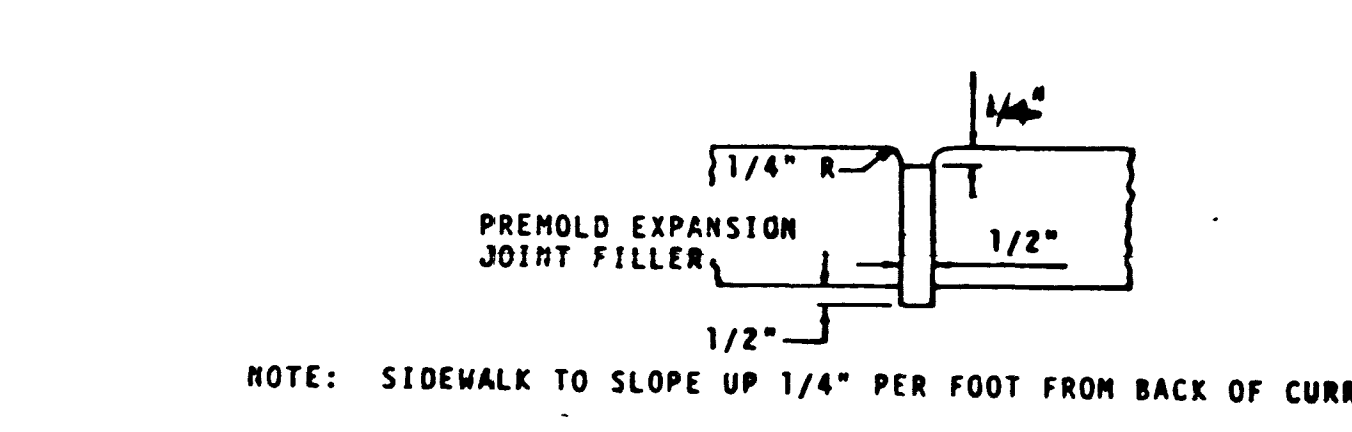
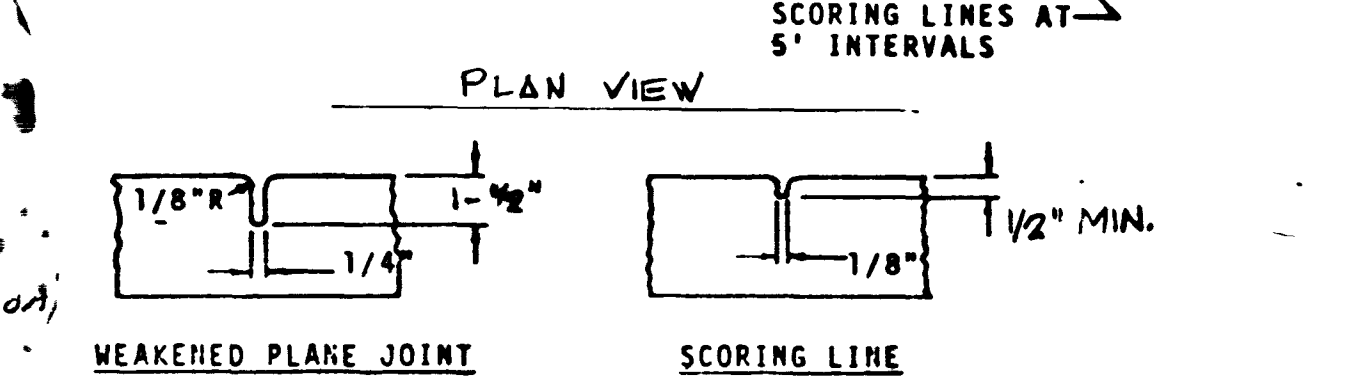
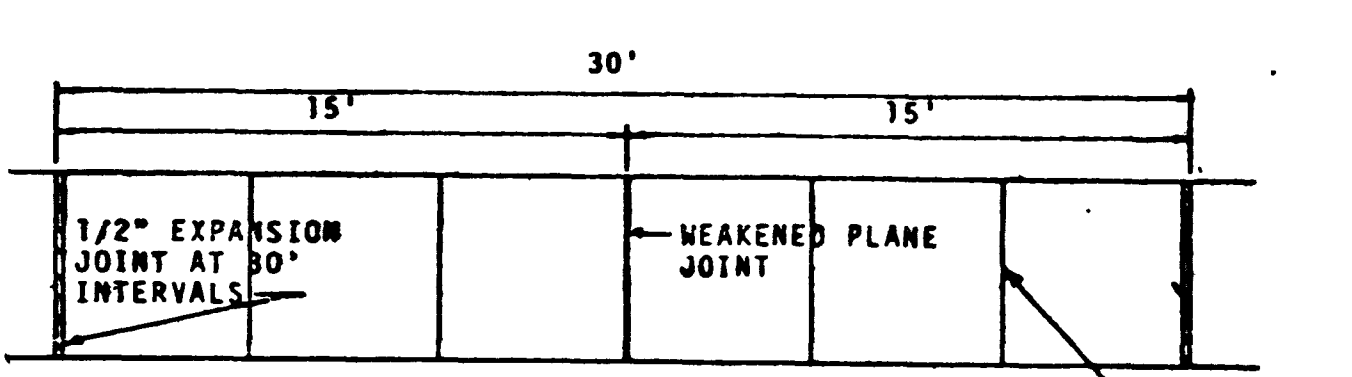
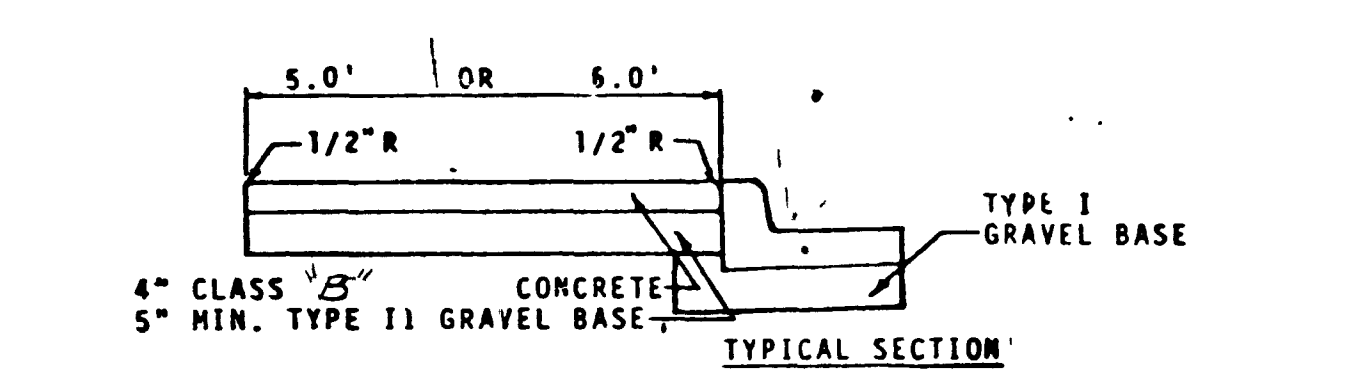

TYPICAL SIDEWALK DETAILS

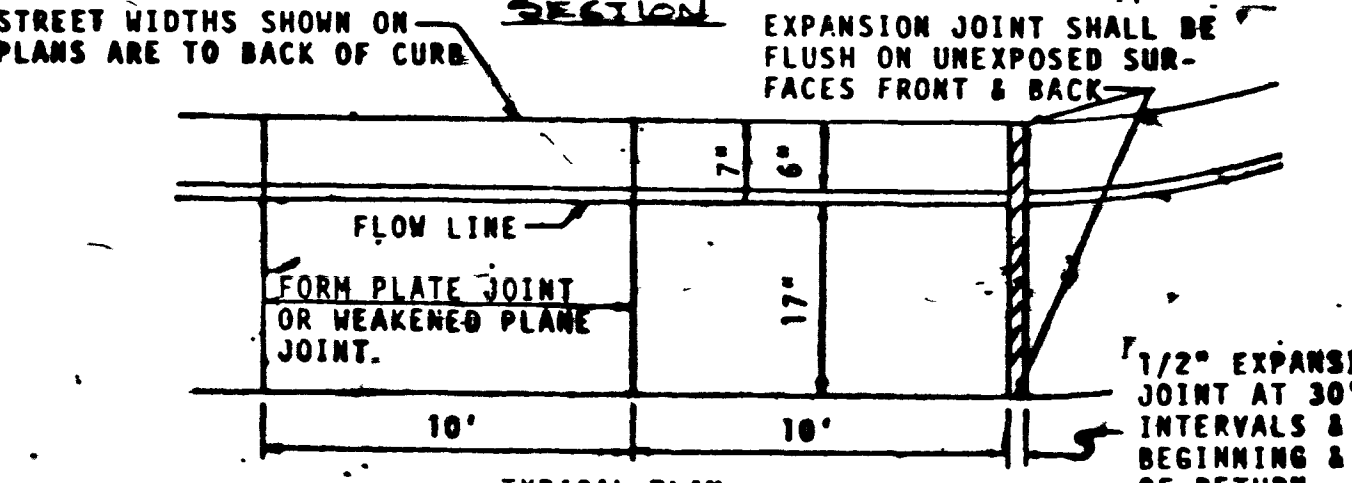
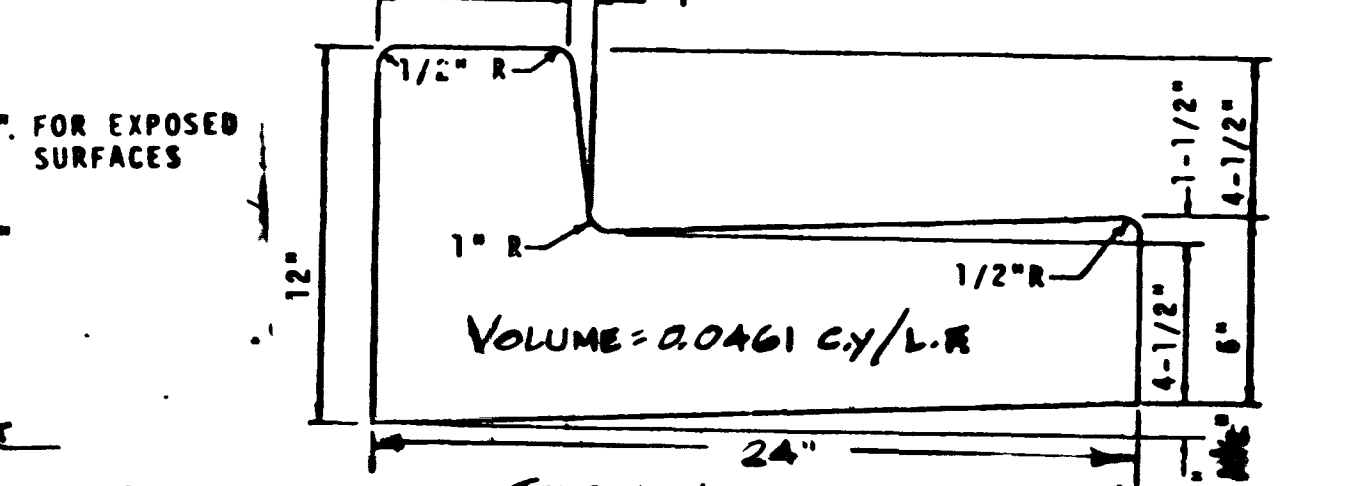

TYP. L-TYPE CURB DET.

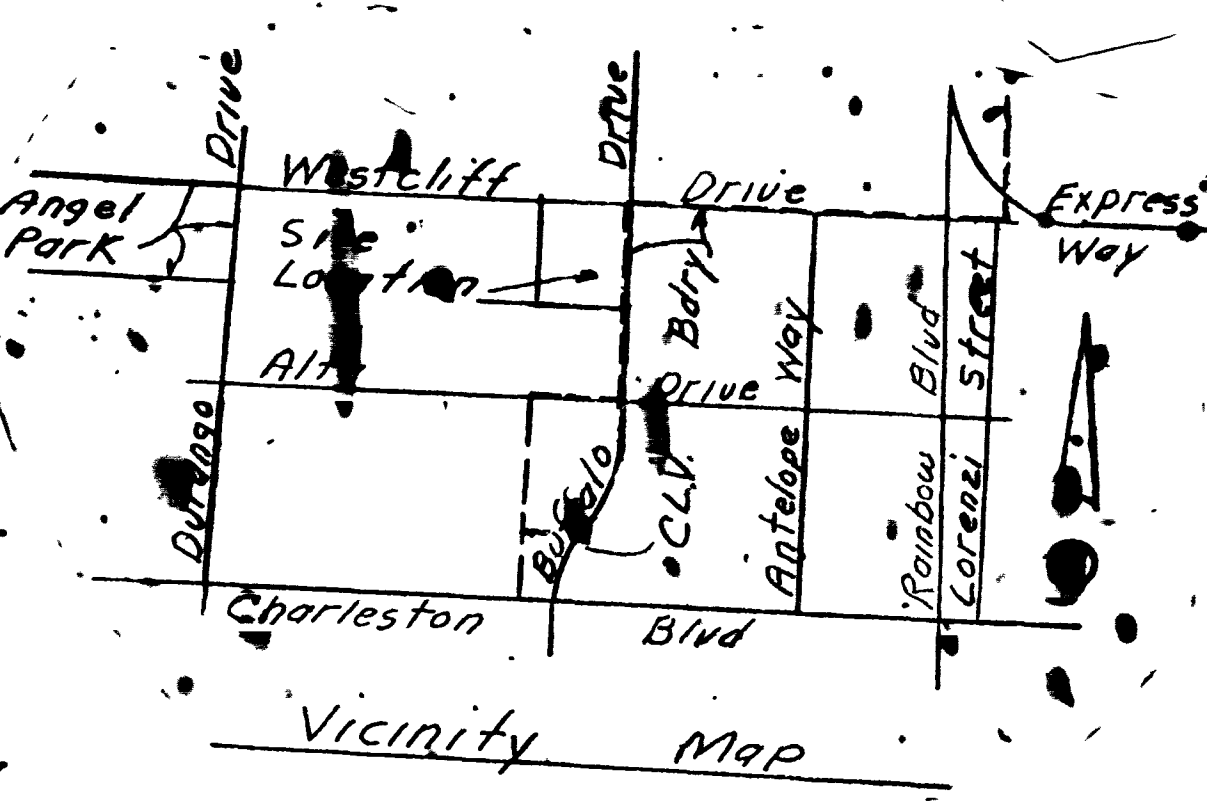

APPROVED
 [Signature] 10/3/78
 CLV CITY ENGINEER DATE
 [Signature] 10-3-78
 CLV FIELD OPERATIONS ENGINEER DATE
 [Signature] 10-3-78
 CLV QUALITY CONTROL ENGINEER DATE

NOTICE TO CONTRACTOR

- Contractor shall provide all necessary horizontal and vertical transition between new construction and existing surfaces to provide for proper drainage and of ingress and egress to said construction. Extent of transitions to be determined by the City Engineer.
- Existing utilities are located on plans for the convenience of the contractor only. The contractor shall bear full responsibility for the protection of utilities and the engineer bears no responsibility for utilities not shown on plans or not in the location shown on the plans.
- Construction to be per Uniform Standard Specifications and Drawings, Clark County Area, Nevada, 1978 Edition.
- TYPE X CEMENT TO BE USED IN ALL CONCRETE QUANTITY ESTIMATE

NO.	ITEM	AMOUNT
1	3" A. C. Paving	701 S.Y.
2	2" A. C. Paving	6203 S.Y.
3	Concrete Valley Gutter (1 Eq)	430 S.F.
4	Curb and Gutter "L" Type	2994 L.F.
5	5' Sidewalk	10385 S.F.
6	6' Sidewalk	1182 S.F.
7	5' x 6" Driveway Approaches (36 Eq)	3600 S.F.
8	6' x 6" Driveway Approaches	S.F.
9	CLV Std Barricade	Eq

ENGINEER'S CERTIFICATE

I hereby certify that these plans and/or specifications comply with F.H.A. objectives, minimum property standards and neighborhood requirements and represents the best of my judgment.

Charley R. Johnson 7/28/78
 Charley R. Johnson RPE Date
 Nev Cert No 3005

VTM CONSULTING ENGINEERS • PLANNERS
 2201 PARKWAY BLVD LAS VEGAS, NEVADA 89102

CHARLESTON RAINBOW UNIT 16C IMPROVEMENT PLANS

SCALE:	WO NO 1066-16C	DATE 7/28/78	SHEET	OF
HORIZ:	DES.	REV.	1	12
VERT:	CHK.	REV.		

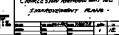
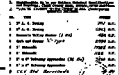
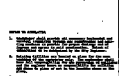
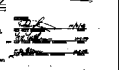
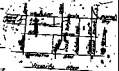
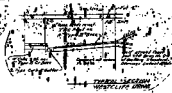
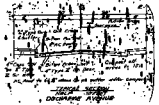
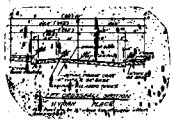

NOTICE
 Clark County Board of Supervisors
 215 West 1st Street, Reno, Nevada
 Open 9:00 AM to 5:00 PM, Monday through Friday
 Phone 775-333-1234

NOTICE
 Clark County Board of Supervisors
 215 West 1st Street, Reno, Nevada
 Open 9:00 AM to 5:00 PM, Monday through Friday
 Phone 775-333-1234

NOTICE
 Clark County Board of Supervisors
 215 West 1st Street, Reno, Nevada
 Open 9:00 AM to 5:00 PM, Monday through Friday
 Phone 775-333-1234