

TYPICAL ROUGH GRADING

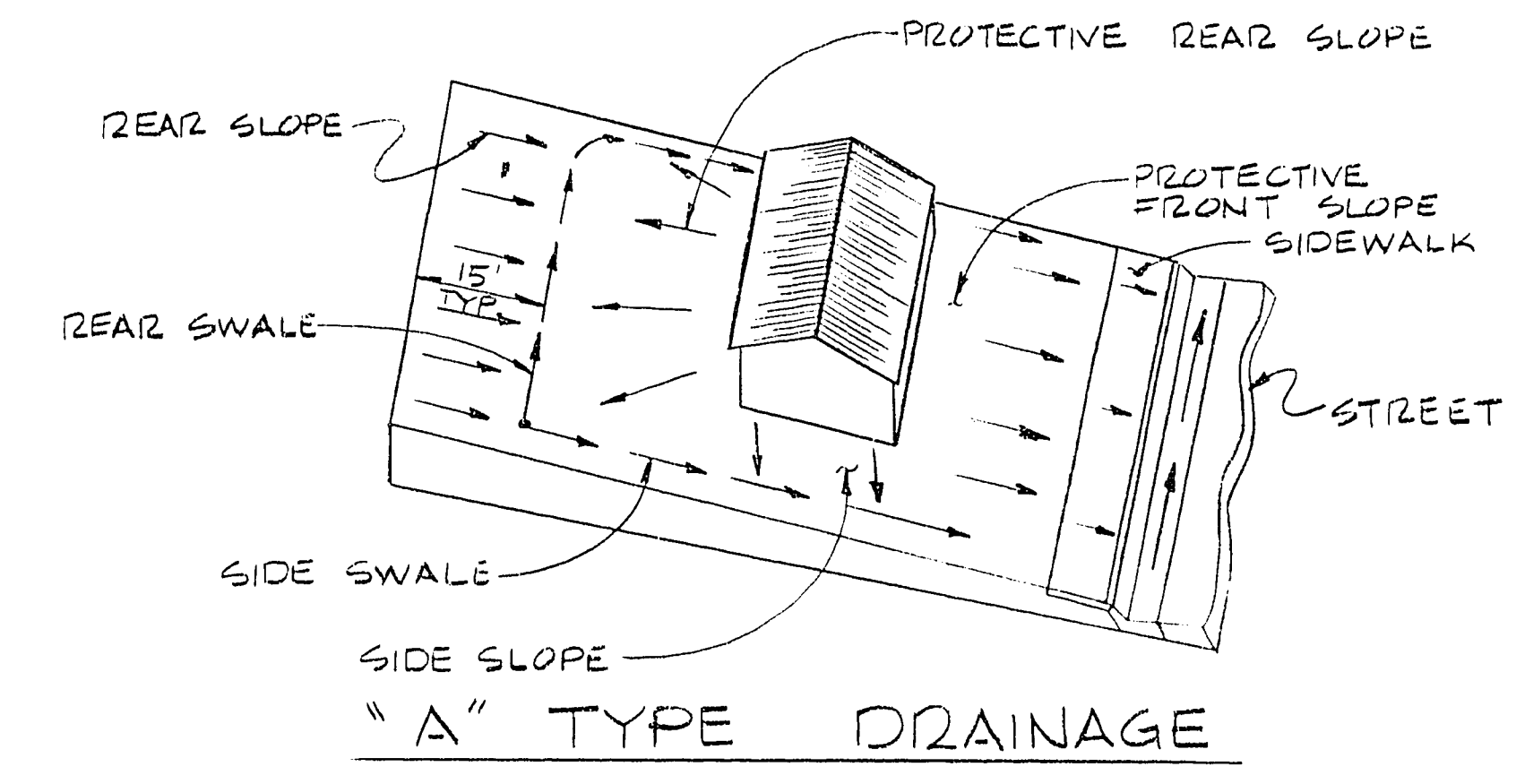

"A" TYPE DRAINAGE

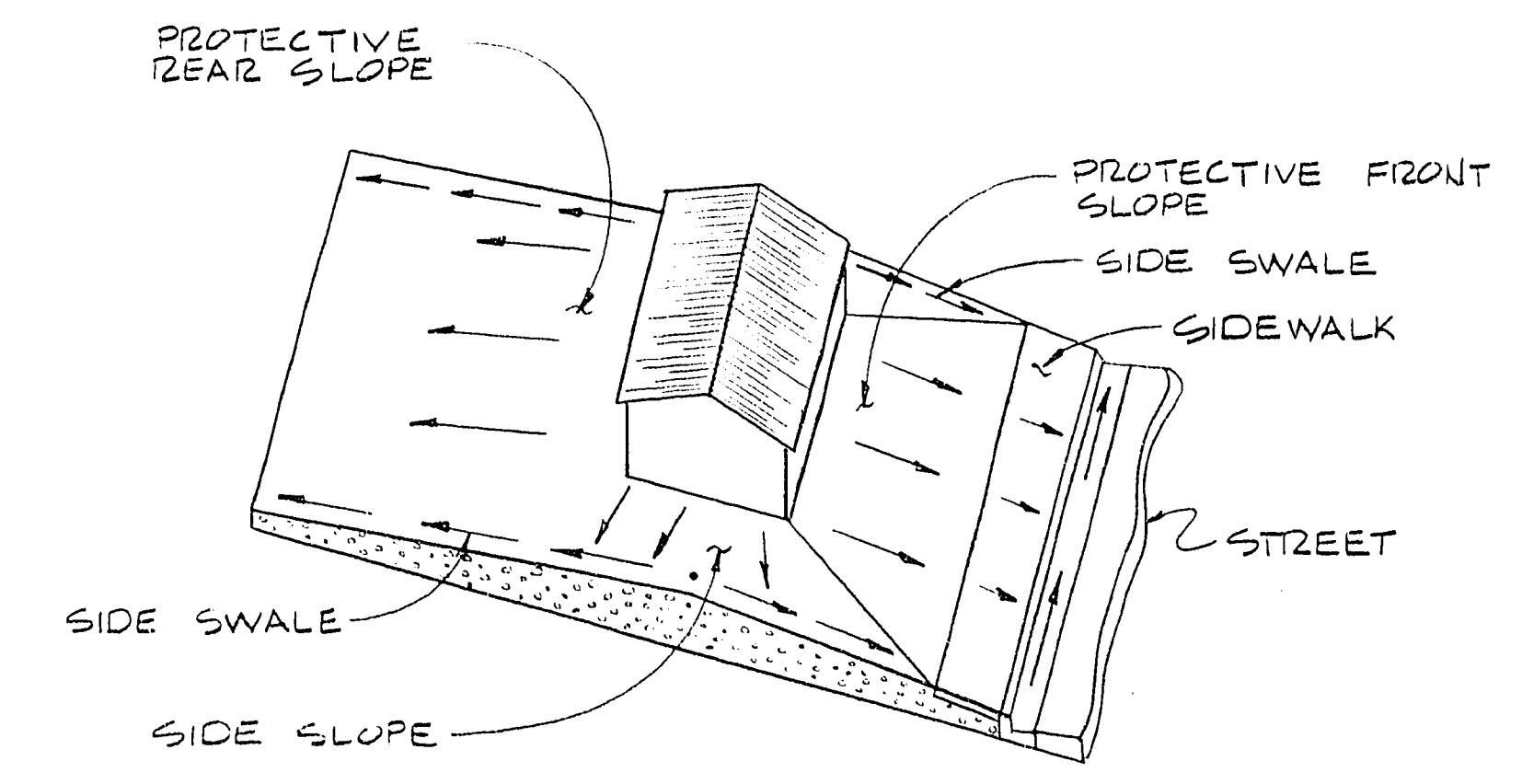

"B" TYPE DRAINAGE

ENCHANTED VILLAGE UNIT NO 1  
BOOK 8, PAGE 52

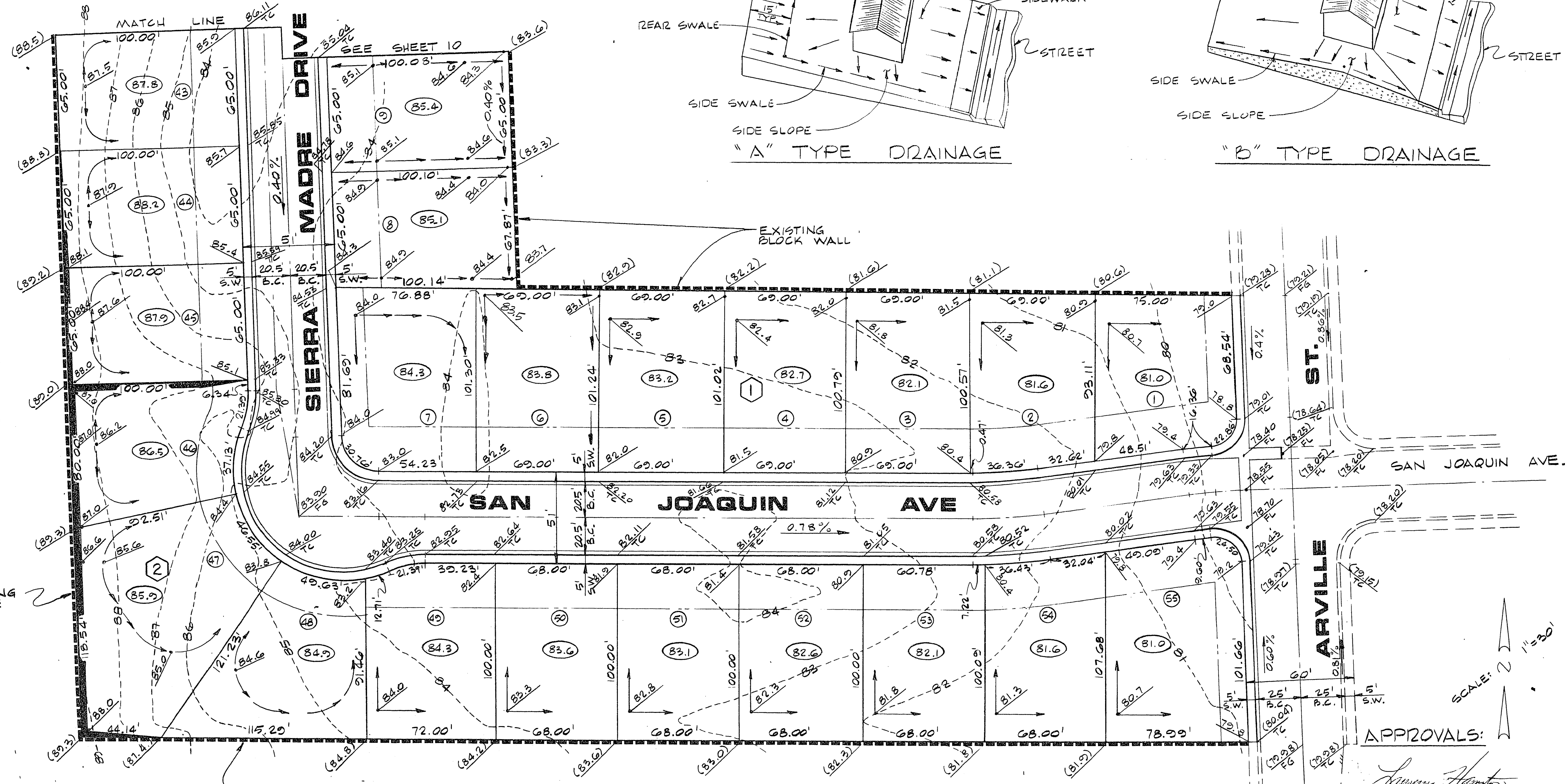

**NOTES**

1. INDICATED GRADES OTHER THAN T.C., F.G. & GUTTER F.L. ARE ROUGH GRADES 0.3' BELOW FINISHED GRADE.
2. LOTS 8 THRU 17, BLOCK 1, ARE F.H.A. TYPE "B" DRAINAGE LOTS. ALL OTHER LOTS ARE F.H.A. TYPE "A" DRAINAGE LOTS.
3. EXCAVATION 12,624 C.Y.

ENCHANTED VILLAGE UNIT NO 1  
BOOK 8, PAGE 52

**LEGEND**

- |        |                |         |  |
|--------|----------------|---------|--|
| (1)    | BLOCK NUMBER   | → →     | DITCH OR SWALE                         |
| (15)   | LOT NUMBER     | - - - - | EXISTING CONTOUR                       |
| (84.3) | PAD GRADE      | - - - - | EXISTING FENCE                         |
| TC     | TOP OF CURB    | - - - - | FRONT YARD SETBACK LINE 25'            |
| FG     | FINISHED GRADE | - - - - | SIDE YARD SETBACK LINE 15'             |
| FL     | FLOW LINE      | - - - - | KNUCKLE & CUL-DE-SAC FRONT SETBACK 20' |
| (34.0) | EXISTING GRADE | █       | 2:1 SCARP                              |
|        |                | █       | CONSTRUCT BLOCK WALL                   |

APPROVALS:

*[Signature]*  
CITY ENGINEER  
DATE 4/24/75

**ENGINEER'S CERTIFICATE**

I HEREBY CERTIFY THAT THESE PLANS AND/OR SPECIFICATIONS COMPLY WITH FHA OBJECTIVES MINIMUM PROPERTY STANDARDS, LOCAL ACCEPTABLE STANDARDS & REQUIREMENTS AND REPRESENTS THE BEST OF MY PROFESSIONAL JUDGEMENT.

*[Signature]*  
G.C. WALLACE - R.P.E.# 1815  
DATE 9/29/75

|     |         |   |
|-----|---------|---|
| REV | DATE    | DESCRIPTION                                   |
| 1   | 12/2/75 | ADDED DRAINAGE SWALE ALONG REAR 10' x 8' x 1' |
| 2   | 1/2/76  | ADDED REAR 10' x 8' x 1'                      |

*[Signature]*  
G.C. WALLACE  
R.P.E.# 1815

**G.C. WALLACE**  
CONSULTING ENGINEER

BECKER & SONS  
CHARLESTON HEIGHTS TRACT NO. 52  
GRADING PLAN I

SHEET  
**9**  
OF 10 SHEETS

288.010