

76-12-107

BOOK 891027 Book 901205

00701 00836

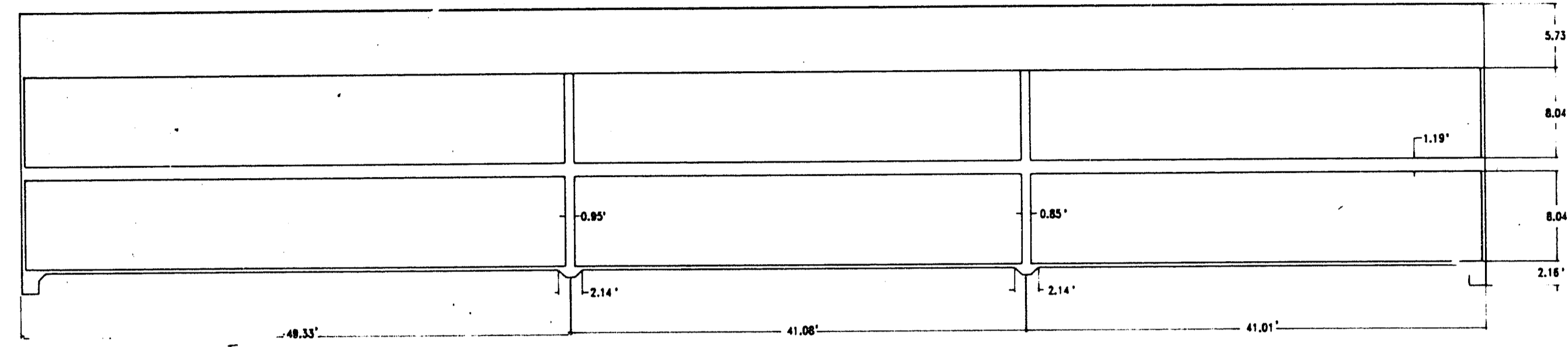

TYPICAL BUILDING SECTION - TYPE "3"
SCALE 1"=10'

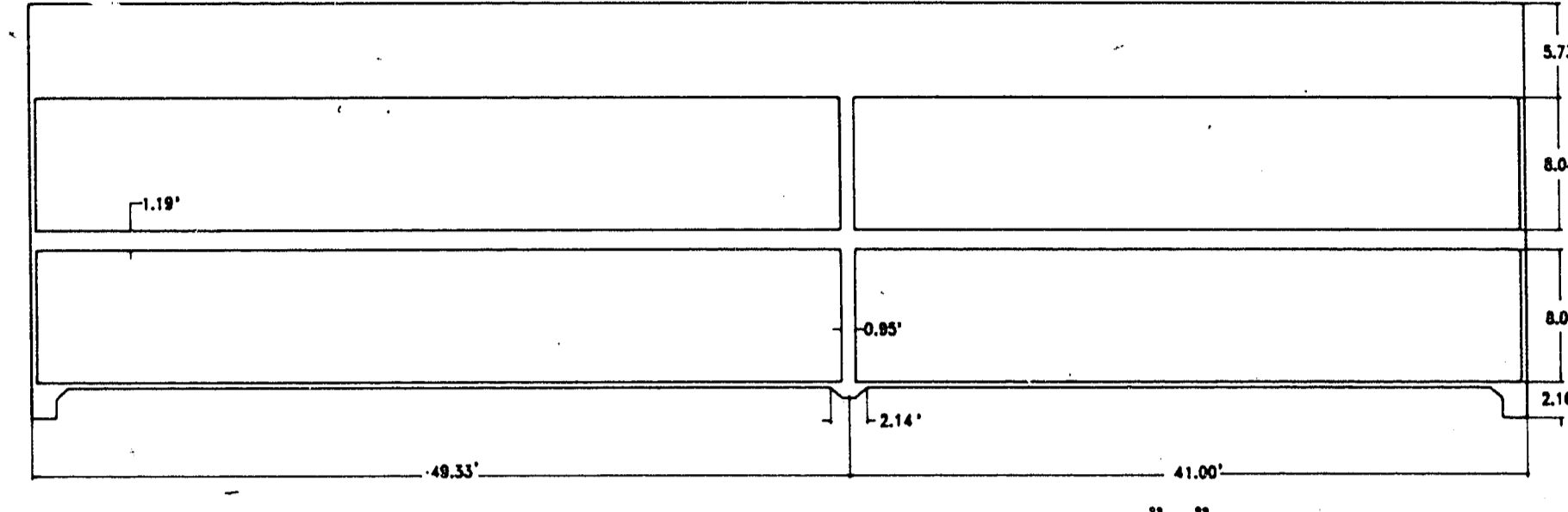

TYPICAL BUILDING SECTION - TYPE "4"
SCALE 1"=10'

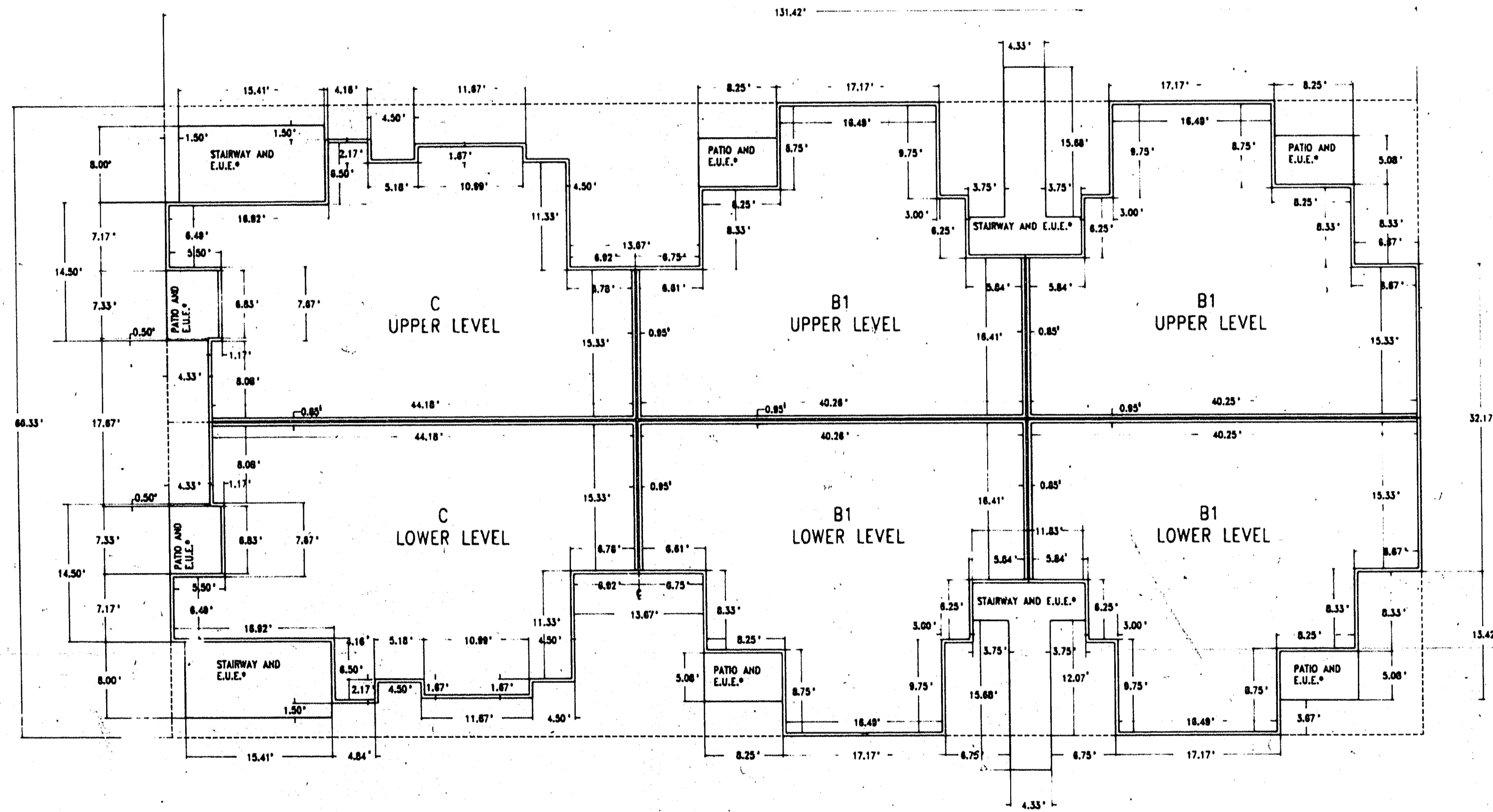

TYPICAL BUILDING PLAN - TYPE "3"
SCALE 1"=10'

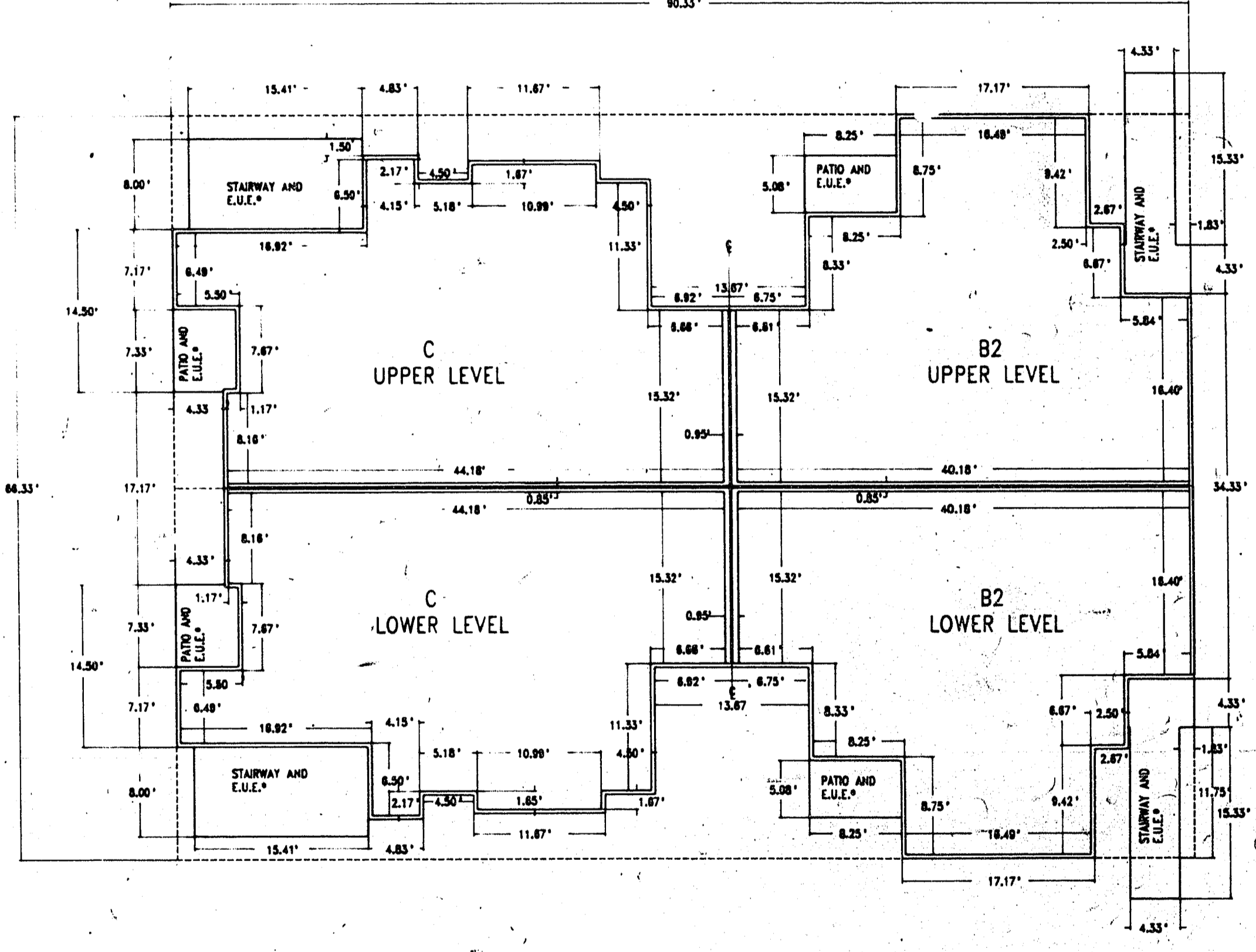

TYPICAL BUILDING PLAN - TYPE "4"
SCALE 1"=10'

AMENDED
OFFICIAL PLAT
OF
PACIFIC HARBORS V
A CONDOMINIUM SUBDIVISION
A PORTION OF THE W 1/2 NW 1/4, SEC. 22, T.20S., R. 60E., M.D.M.
CITY OF LAS VEGAS CLARK COUNTY NEVADA

SPI ENGINEERS/PLANNERS	JOB NO. 394-444
	DESIGNED BY
	DRAWN BY 1000-AB00
	COMP. BY
	CHECKED SL
DATE 5/22/2007	
SHEET NO. 15 OF 58 SHEETS	

4060-V

Book 48 Page 21 BOOK 014 PA 65 007