

**GENERAL NOTES**

ALL CONSTRUCTION SHALL CONFORM TO LEVEL 3 AND CLARK COUNTY AREA UNIFORM STANDARD DRAWINGS AND SPECIFICATIONS.

ALL CONDUIT, PULL BOXES, MANHOLES, TRENCHING, BACK FILLING AND SUBSTRUCTURES ARE TO BE PROVIDED BY THE CONTRACTOR AND CONFORM TO LEVEL 3 STANDARDS UNLESS OTHERWISE SPECIFIED.

TRENCHING AND TELEPHONE BOXES ARE TO BE PLACED IN THE SIDEWALK AREA WHENEVER POSSIBLE. ALL TRENCHING WILL BE OF A MINIMUM DEPTH TO MAINTAIN A 36" COVER OVER ALL LEVEL 3 FACILITIES AND 12" MINIMUM SEPARATION FROM FOREIGN UTILITIES. NEW AND EXISTING BOXES WILL BE ESTABLISHED TO FINISH GRADE.

ALL 90 DEGREE BENDS MUST BE A MINIMUM OF A 48" SWEEP.

ALL PULL BOXES LARGER THAN A 17x30" AND MANHOLES ARE TO BE GROUTED WITH A 3/8" x 1/16" TINNED SOFT COPPER BONDING RIBBON PLACED VERTICALLY AROUND THE BOTTOM OF THE BOX WITH A 3" END STUBBED INSIDE.

PLYWOOD BACKBOARDS ARE TO BE TREATED WITH A FIRE RETARDANT MATERIAL, PAINT OR SEALER.

THE CONTRACTOR SHALL PROVIDE AND INSTALL A MEASURING TAPE CONSISTING OF A WATER PROOF 400 LB. TENSILE STRENGTH MARKED IN ONE FOOT OR LESS INCREMENTS IN AT LEAST ONE DUCTS IN ALL CONDUIT SECTIONS. ALL OTHER DUCTS WILL HAVE A 3/32" JET LINE PULL STRING WITH 400 LB. TENSILE STRENGTH.

THE CONTRACTOR SHALL PROVE AND MANDREL ALL CONDUIT AFTER BACK FILLING WHILE AN LEVEL 3 ENGINEER IS PRESENT. MANDREL SIZE IS TO BE 1/4" SMALLER THAN THE INSIDE DIAMETER OF CONDUIT.

IN ORDER TO INSURE ADEQUATE FACILITIES ARE PROVIDED FOR ON THE PROJECT, IT IS IMPERATIVE THAT THE CONDUIT DESIGN NOT BE CHANGED WITHOUT THE LEVEL 3 ENGINEER'S APPROVAL.

ALL TERMINALS, BACKBOARDS, CABINETS, ETC. SHALL BE EQUIPPED WITH A #6 GAUGE COPPER GROUND WIRE, ATTACHED TO A COMMON POWER MGN.

ALL PULL BOXES AND MANHOLES NOT IN A CONCRETE SIDEWALK, WILL BE REQUIRED TO HAVE A PROTECTIVE 8"x8" CONCRETE COLLAR POURED AROUND THE TOP PORTION OF THE BOX AND H-20 LOAD BEARING LIDS.

ALL CONDUIT ENDS (TERMINATED OR STUBBED) WILL HAVE A TAPERED POLYETHYLENE DUCT PLUG WITH A PULL STRING ATTACHED.

INSPECTION IS REQUIRED FOR ALL PHASES OF THE JOB. THESE PHASES ARE:

- \*OPEN TRENCHES AFTER CONDUIT HAS BEEN PLACED.
- \*OBSERVATION OF BACKFILL AND COMPACTION AS
- \*MEETING STANDARDS
- \*MANDREL OF CONDUIT.
- \*WALL OF PULL BOXES AND MANHOLES MUST BE "CORDED WITH PROPER AMOUNT OF TERMINATIONS.
- \*GROUTING OF PULL BOXES AND CONCRETE COLLARS.
- \*PULL STRING IN ALL CONDUITS

ALL WORK MUST BE ACCEPTED BY LEVEL 3, AS MEETING LEVEL 3 STANDARDS. FOR A CONTRACTOR TO BE PAID AND FOR LEVEL 3 TO PLACE ANY TYPE OF TELECOMMUNICATIONS CABLE/FIBER.

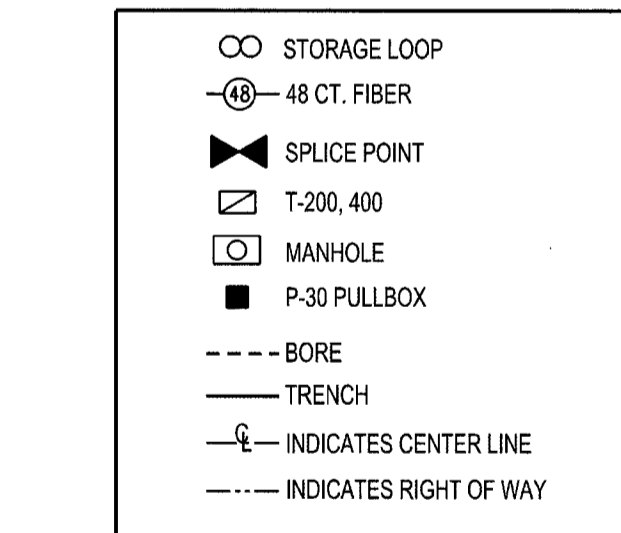

**CONSTRUCTION NOTES:**

COORDINATE CONSTRUCTION WITH LEVEL 3. ALL UG CONDUIT TO BE EQUIPPED WITH LOCATE WIRE. MAINTAIN A MINIMUM OF 36" (PLACE BORE PITS AS NECESSARY)

**UTILITY NOTE**

UTILITY LOCATIONS SHOWN HEREON ARE APPROXIMATE ONLY. IT SHALL BE THE CONTRACTOR'S RESPONSIBILITY TO DETERMINE THE EXACT HORIZONTAL AND VERTICAL LOCATION OF ALL EXISTING UNDERGROUND UTILITIES PRIOR TO COMMENCING CONSTRUCTION. NO REPRESENTATION IS MADE THAT ALL EXISTING UTILITIES ARE SHOWN HEREON. THE ENGINEER ASSUMES NO RESPONSIBILITY FOR UTILITIES NOT SHOWN OR UTILITIES NOT SHOWN IN THEIR PROPER LOCATION.

**811**  
Know what's below. Call before you dig.

CALL BEFORE YOU DO OVERHEAD CALL: 1-702-227-2929  
CALL BEFORE YOU UNDERGROUND CALL: 1-702-432-5200

- CONSTRUCTION NOTES:**
- REMOVE AND REPLACE SIDEWALK
  - TRENCH IN SIDEWALK AREA
  - INSTALL 1-1" INNERDUCT
  - INSTALL 2-2" CONDUIT
  - INSTALL P-30 PULLBOX
  - BORE PIT
  - DIRECTIONAL BORE 3 FT. (3'-5" +/- 10%) FROM FINISH GRADE
  - PULL 1-48 CT. FIBER

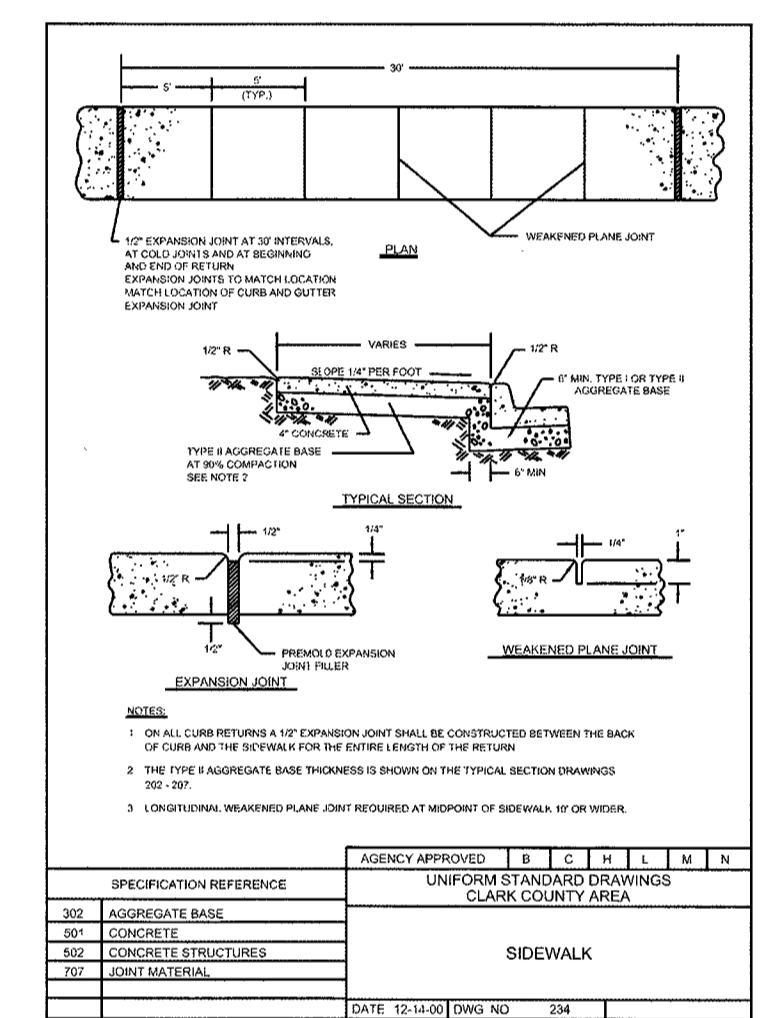
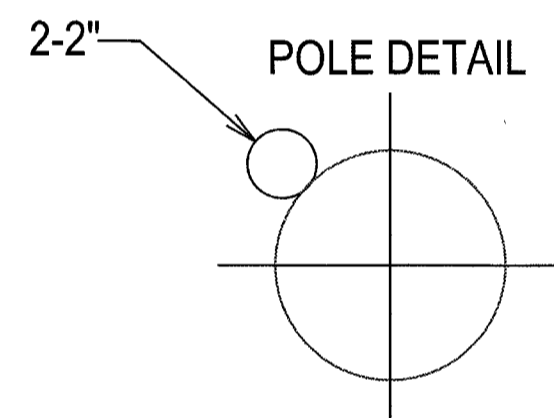
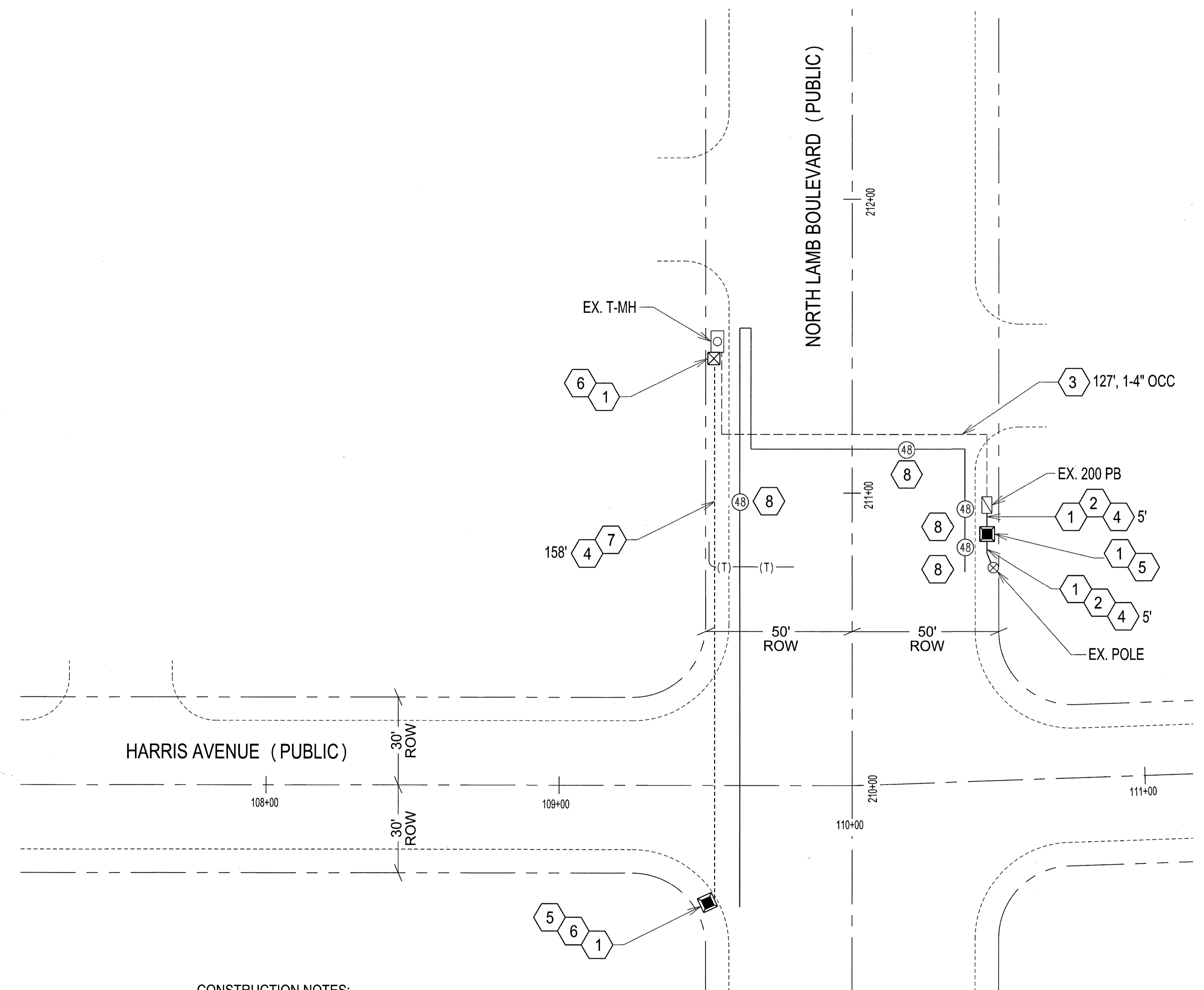

NOTE: ALL WORK SHALL COMPLY WITH THE CCAU STANDARD DRAWINGS.

City of Las Vegas  
APPROVED FOR CONSTRUCTION  
THIS APPROVAL IS FOR WORK IN CLV R/W OR CLV EASEMENT ONLY. OBTAINING PERMISSION OR EASEMENT FOR WORK SHOWN ON PRIVATE PROPERTY IS THE RESPONSIBILITY OF THE UTILITY.

Approval: *[Signature]* Date: 8/17/17  
L17-00268 107V6961-718

CITY OF LAS VEGAS PUBLIC WORKS PERMIT REQUIRES\*

DEVELOPER/CONTRACTOR SHALL OBTAIN A CITY OF LAS VEGAS (CLV) PERMIT BEFORE ANY EXCAVATION WORK WITHIN CITY OF LAS VEGAS RIGHT-OF-WAY

\*LEVEL 3 INSPECTOR WILL VERIFY CITY OF LAS VEGAS PERMIT FOR WORK DONE WITHIN CLV RIGHT-OF-WAY

INSPECTOR: \_\_\_\_\_ DATE: \_\_\_\_\_

REVISIONS	DESCRIPTION	NUMBER	DATE

SCALE (H) 1"=20'

PROJECT NAME: 760 N. Lamb Boulevard  
PROJECT LOCATION: North Lamb Boulevard and Harris Avenue  
PROJECT NUMBER: L317005

**Level 3**  
COMMUNICATIONS  
3944 East Silverthorn Lane  
Las Vegas, NV 89120  
Office: 702.216-2233, Fax: (702) 216-2299

SHEET 1  
1 of 1 SHEETS

L17-00268 7/6/17