

CITY OF LAS VEGAS, NEVADA

PERMIT NO.

DEPARTMENT OF BUILDING AND SAFETY
PHONE 386-6251



2071

BUILDING PERMIT
FOR: Single Family Dwelling, Remodel
Additions, Misc. Residential Construction

LOG NO. & AREA ATTACHED M-4703 DATE 9/27/90 CONST. VAL. \$ 1400

ADDRESS OF CONSTRUCTION 8513 SONETO LN. OWNER MRS & MRS. HUNT PHONE 253-8436

LOT(s) 3 BLOCK 3 SUBDIVISION Valley West 11-1 ZONE R

PROPOSED CONSTRUCTION PATIO COVER USE _____

THIS PERMIT FOR BLDG. A/C ELEC. PLBG. OTHER PERMITS REQD.: FENCE OFF SITE SWIM POOL

FLOOR AREA BSMT _____ 1ST _____ 2ND _____ GARAGE _____ PORCH 264 TOTAL 264

CONTRACTOR ALAN JESKEY BLDGS. STATE LICENSE NO. 29370 CITY LICENSE NO. 041382

ARCHITECT _____ ENGINEER _____

MASTER PLUMBER/CONTRACTOR _____ MASTER ELECTRICIAN/CONTRACTOR _____

OTHER INSPECTIONS AND FEES

- Inspections outside of normal business hours = \$30.00 per hour (minimum charge three hours).
- Re-inspection fee during normal business hours assessed under provisions of TABLE 3-A of the Uniform Building Code = \$30.00 per hour.
- Inspections during normal business hours for which no fee is specifically indicated = \$30.00 per hour (minimum charge one half hour).
- Additional plan review required by changes, additions, or revisions to approved plans = \$30.00 per hour (minimum charge two hours).

CONDITIONS OF THE PERMIT:

- I agree to call the City Building Department for inspections before concrete is poured, before rough wiring, electrical, plumbing, framing is covered. Also for air conditioning, drywall and sheathing inspection.
- I agree that when the job is completed that I will call for final inspection before occupancy.
- I agree to perform all construction in accordance with City Ordinances and Building Codes.
- The Contractor's signature below denotes authority from the owner to sign in his behalf and that the owner is aware of all requirements of this application and permit. Separate permits must be taken out for work outlined above this agreement.
- I have read and understand the contents of this application and permit; I hereby state that the information I have supplied on this application is true and correct.
- Approval for the work under this permit will be given only after refuse and debris have been removed from job site and public right of way.
- 24 HOUR MINIMUM NOTICE REQUIRED FOR INSPECTIONS.

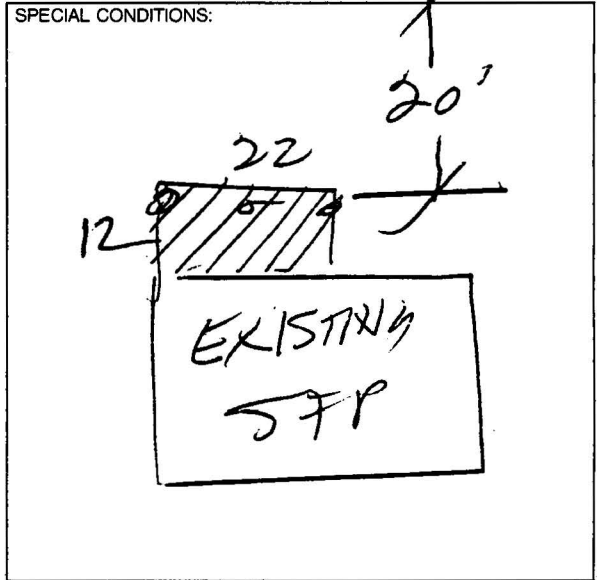

BY: _____ I HEREBY DECLARE THAT I AM THE LEGAL OWNER OF THE ABOVE PROPERTY OWNER

BY: Alan Jeskey AGENT

I hereby certify that I have reviewed this application and the proposed plans and have found that the proposed development meets the requirements of the City of Las Vegas Flood Hazard Reduction Ordinance for the issuance of this Development Permit.

LAND DEVELOPMENT AND FLOOD CONTROL ENGINEER _____ DATE 9/27/90

PLANNING DEPT. [Signature] DATE 9/27/90

BUILDING DEPT. _____ DATE _____

PLUMBING	FEE	ELECTRICAL	FEE
WATER DISTRIBUTION	6.00	RECEPTACLE _____ SWITCH _____	.40
SEWER SYSTEM - NEW OR MODIFICATION	10.00	EACH LIGHT FIXTURE OR SOCKET _____	.30
FIXTURES - WATER SOFTENER, H.W. HEATER	2.00	SPECIAL OUTLET, APPLIANCE ETC.	.70
GARBAGE DISPOSAL - WASHER	2.00	SERVICE/PANEL - SUB/3.00 - 200A/6.00 - 400A/12.50	
FUEL PIPING	6.00	A.C. UNIT OR MOTORS	3.00
IRRIGATION SYSTEM	8.00	2310 - 2432	TOTAL
MISC.		MISC.	
2310 - 2433	TOTAL	2310 - 2431 ISSUANCE FEE	
AIR CONDITIONING	FEE	7 143 - 2973 SEWER CONNECTION	
NEW UNIT - 3 TON = 9.00 OVER = 16.50		2310 - 2431 PLAN REVIEW FEE	<u>28.30</u>
FURNACE TO 100,000/9.00 OVER/11.00		2310 - 2431 BLDG. PERMIT FEE	<u>28.50</u>
VAPORATIVE COOLER	6.50	TOTAL FEES	<u>56.80</u>
VENTILATION FAN	2.35		
2310 - 2435	TOTAL		

RECEIPT
84110548
571 00.00
0800 00.00
23324000 10.00

9/27/90

PERMIT NO. _____ MUST BE MACHINE VALIDATED

CLASS "C" BUILT-UP ROOFING OR BTR.
(MAY CONSIST OF 3 LAYERS TYPE 15
FIBER FELT AND 1 LAYER OF MINERAL
SURFACE CAP SHEET APPLIED PER
MFG. INSTRUCTIONS)

PATIO COVER CONVERTIBLE TO HABITABLE SPACE

**PLANS APPROVED
CONSTRUCTION**
Building & Safety Dept.
City of Las Vegas, Nevada

NM SEP 27 1990

Does not include Electrical, Plumbing
Or Air-Sea Improvements
Make No Change Without Approval
Approval Of Plan Ins NOT A
Violate ANY Code

MIN. 1/4" : 1'-0"
ROOF SLOPE

MATERIAL LIST

DIMENSIONS _____ X _____ LEDGER SIZE _____

RAFTER SIZE _____ SPACING _____

POST SIZE _____ SPACING _____

BEAM SIZE _____ SPAN _____

LUMBER TO BE DOUGLAS FIR-LARCH, #2 GRADE OR
BETTER. PLYWOOD TO BE 1/2" THK. EXPOSURE I APA
RATED SHEATHING WITH 24/0 PANEL IDENTIFICATION.

WIDTH OF WALL OPEN'G.	4'-0"	6'-0"	8'-0"
LEDGER SIZE	2X6	2X8	2X10
BOLTS REQ'D.	3-BOLTS/ EA. END	4-BOLTS/ EA. END	5-BOLTS/ EA. END

NOTE: ALL LAG BOLTS TO BE 3/8" DIA.
BY 4" LONG.

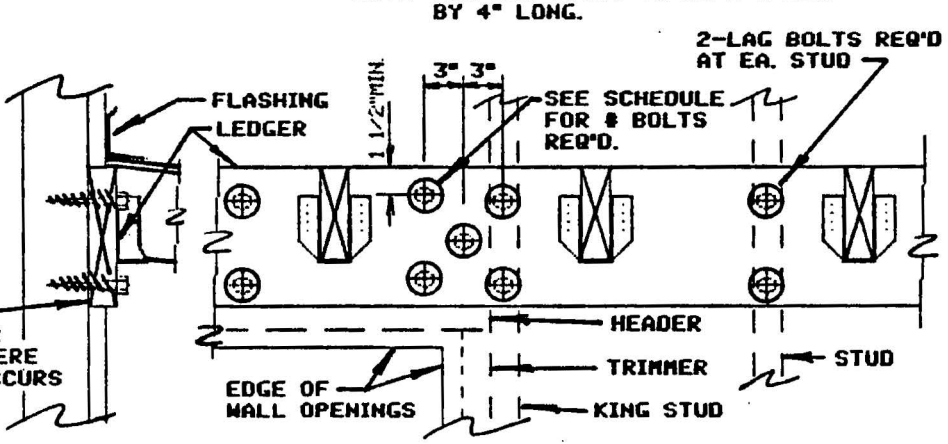
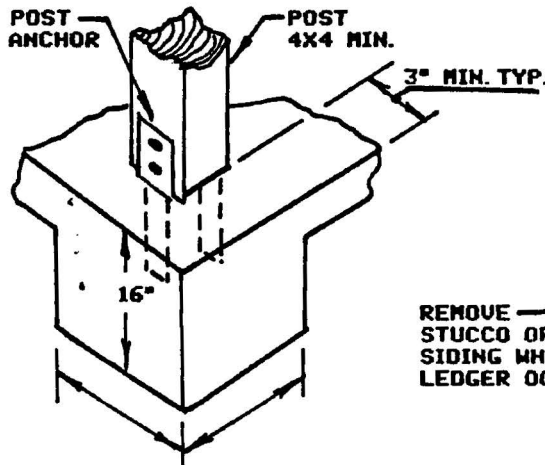
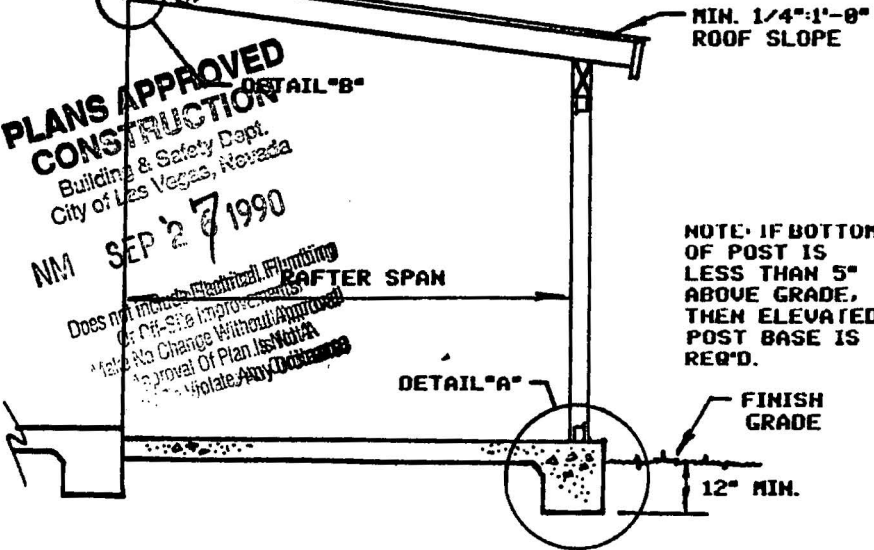

DETAIL "A"

DETAIL "B"

SPAN OF RAFTERS		8'-0"	10'-0"	12'-0"	14'-0"	16'-0"
RAFTER SELECTION		2X6@24"O.C.	2X6@24"O.C.	2X8@24"O.C.	2X10@24"O.C.	2X10@24"O.C.
SPACING OF COLUMNS	6'-0"	BEAM 4X4	4X6	4X6	4X6	4X6
		FOOTINGS 13"SQ.	14"SQ.	15"SQ.	16"SQ.	17"SQ.
	8'-0"	BEAM 4X6	4X6	4X6	4X8	4X8
		FOOTINGS 15"SQ.	17"SQ.	18"SQ.	19"SQ.	20"SQ.
	10'-0"	BEAM 4X8	4X8	4X8	4X8	4X10
		FOOTINGS 17"SQ.	19"SQ.	20"SQ.	21"SQ.	22"SQ.
	12'-0"	BEAM 4X8	4X10	4X10	4X10	4X10
		FOOTINGS 19"SQ.	20"SQ.	22"SQ.	23"SQ.	24"SQ.
	14'-0"	BEAM 4X10	4X10	4X10	4X12	4X12
		FOOTINGS 20"SQ.	22"SQ.	23"SQ.	25"SQ.	26"SQ.
	16'-0"	BEAM 4X10	4X12	4X12	4X12	4X14
		FOOTINGS 22"SQ.	23"SQ.	25"SQ.	26"SQ.	28"SQ.

**PATIO
COVER
DETAILS**

OWNER: _____

ADDRESS: _____

**CITY OF LAS VEGAS
DEPARTMENT of
BUILDING & SAFETY**



DEPARTMENT OF BUILDING & SAFETY CITY OF LAS VEGAS

JOB ADDRESS 85.13 Soneto Lane			PERMIT NO. 84026
LOT NO.	MAP NO. 11-216P	INSPECTOR 51	DATE 9-28-90
SUBDIVISION NAME			PHONE
INSPECTOR SIGNATURE G. Shoemaker			INSPECTION DATE 10-1

patio

PARTIAL INSPECTION - DESCRIPTION:

APPROVED

 PERMIT REQUIRED

 STOP WORK

REJECTED - CORRECTION NOTICE - REINSPECTION REQUIRED CALL 799-2071

INSPECT	DESCRIPTION	INSPECT	DESCRIPTION	INSPECT	DESCRIPTION
<input type="checkbox"/> B-1	FOOTING, LAYOUT, REBAR, ZONING	<input type="checkbox"/> P-1	ON SITE SEWER	<input type="checkbox"/> X-2	UNDERGROUND HYDRO
<input type="checkbox"/> B-2	STEM WALL - FORMS & REBAR	<input type="checkbox"/> P-2	ON SITE WATER	<input type="checkbox"/> X-3	UNDERGROUND FINAL/FLOW
<input type="checkbox"/> B-3	PRE-SLAB	<input type="checkbox"/> P-3	BUILDING SEWER (YARD LINES)	<input type="checkbox"/> X-4	SPRINKLER SYSTEM HYDRO
<input type="checkbox"/> B-4	ROOF SHEATHING	<input type="checkbox"/> P-4	UNDERSLAB PLUMBING	<input type="checkbox"/> X-5	FIRE ALARM
<input checked="" type="checkbox"/> B-5	FRAMING	<input type="checkbox"/> P-5	TOP OUT-WATER, GAS, WASTE	<input type="checkbox"/> X-6	OTHER:
<input type="checkbox"/> B-6	INSULATION	<input type="checkbox"/> P-6	FINAL GAS TEST	<input type="checkbox"/> X-7	FINAL FIRE
<input type="checkbox"/> B-7	DRYWALL NAILING	<input type="checkbox"/> P-7	FINAL PLUMBING		
<input type="checkbox"/> B-8	EXTERIOR LATH/STUCCO			<input type="checkbox"/> E-1	UNDERGROUND ELETTRICAL
<input type="checkbox"/> B-9	WALL GROUT & STEEL	<input type="checkbox"/> M-1	ROUGH VENT	<input type="checkbox"/> E-2	ROUGH ELECTRICAL
<input type="checkbox"/> B-10	POOL PRE-GUNITE	<input type="checkbox"/> M-2	HOOD	<input type="checkbox"/> E-3	LOW VOLTAGE ELECTRICAL
<input type="checkbox"/> B-11	POOL PRE-PLASTER / FINAL	<input type="checkbox"/> M-3	FINAL MECHANICAL	<input type="checkbox"/> E-4	SIGN INSPECTION
<input checked="" type="checkbox"/> B-12	BUILDING FINAL			<input type="checkbox"/> E-5	FINAL ELECTRICAL
<input type="checkbox"/> B-13	CERT. OF OCC.	<input type="checkbox"/> X-1	KICKER / FLUSH	<input type="checkbox"/> E-6	TEMP POWER

FINAL INSPECTION

BRING HARD CARD WITH FIRE, QUALITY CONTROL & PLANNING APPROVALS SIGNED OFF TO BLDG & SAFETY FOR C. of O. ISSUANCE (Commercial Only)

FOR ASSISTANCE -CALL: 388-8251